

The moment of a force about a point is the turning effect of a force on a rigid body. The moment, sometimes also called the torque, is something that comes up all the time in mechanics. It is critical that you can calculate moments quickly and accurately. Working with moments will give you lots of practice on your trig skills.

There are several methods available to find a moment, and you want to choose the method that is easiest for a given situation, therefore you need to get familiar with the available methods.

The methods you can use are:

1. Using the **definition** of the moment

$$M = F d_{\perp}$$

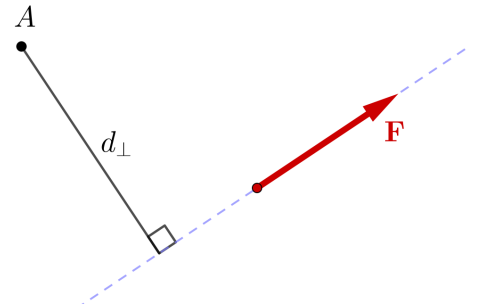

2. Using the **perpendicular component** of the force. This method is mathematically identical to method 1.

$$M = F_{\perp} d$$

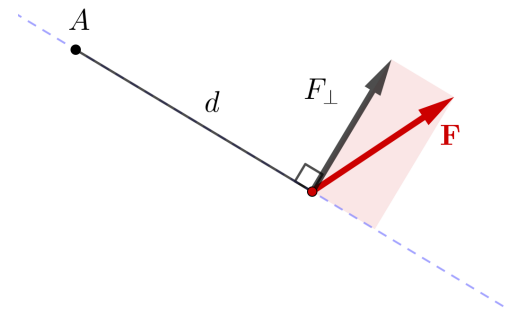

3. Using **Varignon's Theorem**.

$$M = \pm F_x d_y \pm F_y d_x$$

Resolve the force into  $x$ - and  $y$ - components then add their moments. You must account for the direction of the two moments to determine the correct direction of the resultant moment. In this course, the convention is that Counterclockwise moments are positive.

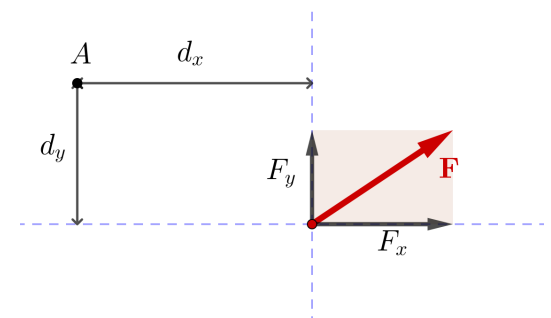

Sometimes its helpful to slide the force along its line of action to a more convenient position, then use one of the above methods.

The interactive in [Figure 4.4.4](#) in the online textbook, may help you develop your visualizaion skills.

**Example 1**

Calculate the moments of forces  $A$  and  $B$  about point  $O$  using Varignon's Theorem.

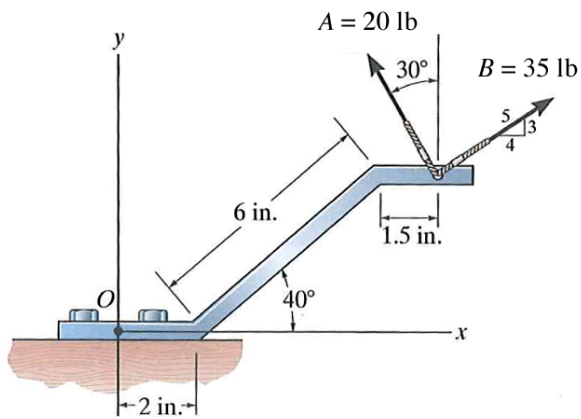

**Example 2**

Calculate the moment of the 100 lb force about point  $A$ . What angle  $\alpha$  would produce the maximum moment about  $A$ ?

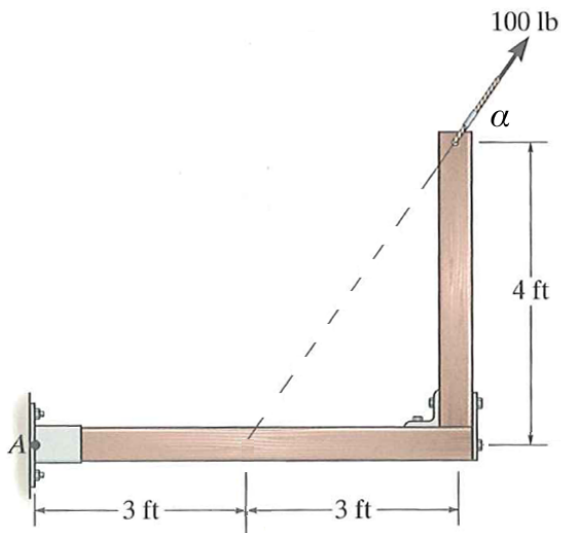

**Example 3**

It is known that the connecting rod  $AB$  exerts on the crank  $BC$  a 1.5 kN force directed down and to the left along the centerline of  $AB$ . Determine the moment of that force about  $C$ .

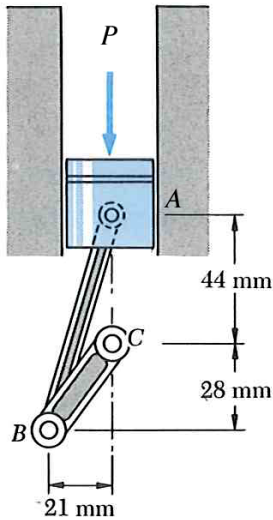

**Example 4**

The oven door is supported by two identical springs, and a hinge at point  $A$ .

Determine the force needed in each spring if the resultant moment about point  $A$  of the weight and the spring forces is zero when angle  $\alpha$  is  $45^\circ$ .

