

1. The tension in cable AB is 100 N. Determine the moment about O of this tension as applied to point A of the T-shaped bar. The dimension b is 600 mm.

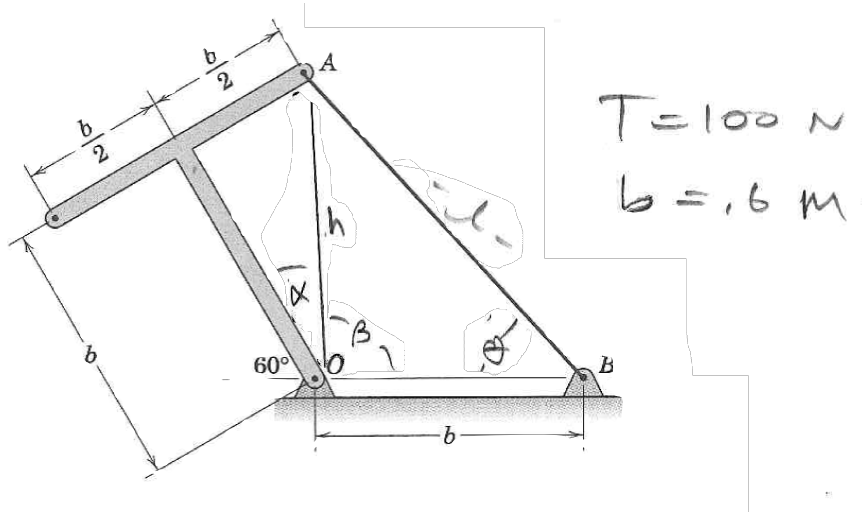

$$\alpha = \tan^{-1} \frac{b/2}{b} = \tan^{-1} \frac{1}{2} = 26.5^\circ$$

$$\beta = 180 - 60 - \alpha = 93.4^\circ$$

$$h = \sqrt{b^2 + \left(\frac{b}{2}\right)^2} = b\sqrt{1.25} = 1.118b$$

$$\frac{\text{L.O.C.}}{d^2} = b^2 + (b\sqrt{1.25})^2 - 2(b)(\sqrt{1.25}b) \cos \beta =$$

$$d^2 = b^2 (1 + 1.25 - (2\sqrt{1.25})(\cos \beta)) = 2.38b^2 \Rightarrow d = 1.544b$$

$$\frac{h}{\sin \theta} = \frac{d}{\sin \beta} \Rightarrow \sin \theta = \frac{h \sin \beta}{d} \Rightarrow \theta = 46.29^\circ$$

$$M_o = (T \sin \theta)(b) = 43.6 \text{ N}\cdot\text{m}$$

2. Determine the moments of the tension T about point P and point O .

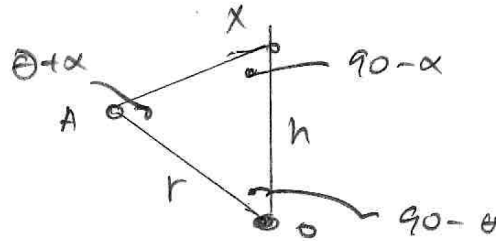
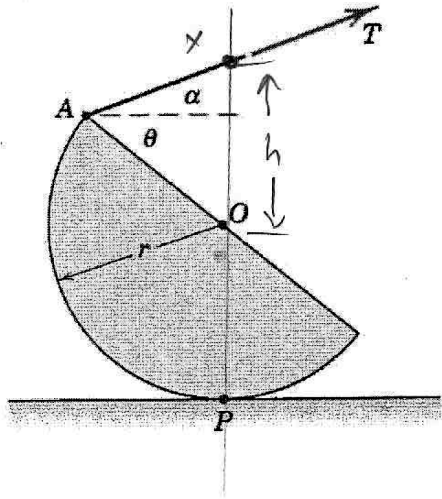

$$\frac{h}{\sin(\theta + \alpha)} = \frac{r}{\sin(90 - \alpha)}$$

$$h = \frac{r \sin(\theta + \alpha)}{\cos \alpha}$$

$$M_P = (r + h)(T \cos \alpha)$$

$$= r \left(1 + \frac{\sin(\theta + \alpha)}{\cos \alpha} \right) (T \cos \alpha)$$

$$= r (\cos \alpha + \sin(\theta + \alpha)) T$$

$$M_O = r T (\sin(\theta + \alpha))$$