

PATRIOT STATE
(Santa Mercedes)
James River Reserve Fleet
Newport News vicinity
Virginia

HAER VA-135
HAER VA-135

PHOTOGRAPHS

WRITTEN HISTORICAL AND DESCRIPTIVE DATA

FIELD RECORDS

HISTORIC AMERICAN ENGINEERING RECORD
National Park Service
U.S. Department of the Interior
1849 C Street NW
Washington, DC 20240-0001

HISTORIC AMERICAN ENGINEERING RECORD

PATRIOT STATE (*Santa Mercedes*)

HAER No. VA-135

Location: James River Reserve Fleet, Newport News vicinity, Virginia

Type of Craft: Cargo/passenger vessel, later school training ship

Trade: Commerce, later education

Class: *Santa Magdalena*

Official No.: 293943

Principle Dimensions: Length (oa): 546'-7 ⁵/₈"
Beam: 79'-1"
Draft: 29'-1"
Displacement: 19,799 long tons
(The listed dimensions are as built, but it should be noted that draft, displacement, and tonnages were subject to alteration over time as well as variations in measurement.)

Dates of Construction: 9 September 1962 – 7 April 1964

Designer: George G. Sharp Company, New York, New York

Builder: Bethlehem Steel Company, Sparrows Point, Maryland

Present Owner: U.S. Maritime Administration

Significance: The *Patriot State* is significant as an example of a bold new design ordered by and built for the Grace Line shipping company. The vessel's plan incorporated the latest technology to carry bulk cargo and passengers from the United States to South America and back. The *Patriot State* is also significant for its use as a training vessel by the Massachusetts Maritime Academy.

Historian: Brian Clayton, HAER Contract Historian, summer 2006

Project Information: This project is part of the Historic American Engineering Record (HAER), a long-range program to document historically significant engineering and

industrial works in the United States. The Heritage Documentation Programs of the National Park Service, U.S. Department of the Interior, administers the HAER program.

The project was prepared under the direction of Todd Croteau (HAER Maritime Program Coordinator). Jet Lowe (HAER Photographer) produced the large-format photographs. Special thanks go to Erhard Koehler (U.S. Maritime Administration) whose help and assistance greatly benefited this project.

BACKGROUND

Established in 1950 and based on the U.S. Maritime Commission (1936-1950) and the U.S. Shipping Board (1916-1935), the U.S. Maritime Administration assisted U.S. shipping lines by subsidizing ship construction and operations. By so doing, it promoted the U.S. Merchant Marine, made up of civilian-owned merchant vessels.¹ The Maritime Administration supervised two important programs that helped shipping lines: the operating-differential subsidy (ODS) and the construction-differential subsidy (CDS).² These two programs helped defray the costs of U.S. shipping lines competing against foreign firms. The Grace Steamship Company, commonly known as Grace Line, was one such company that accepted subsidies from the government. The subsidies underpinned its construction of the *Santa Magdalena* class, which included the *Santa Mercedes*, as the *Patriot State* was originally named.³

The company that came to be known as the Grace Line started as a small operation in 1882 under the direction of two Irish brothers, William and Michael Grace, who worked in Peru. Their business centered on the export of guano from the Chincha Islands to the United States. In 1865, William Grace left Peru due to physical ailments and opened W.R. Grace and Company in New York, while his brother Michael remained in Callao, Peru, to continue the export trade. William purchased a line of sailing ships in 1882 and began running service from New York to Peru under the British flag. Routine service to South America began in 1893 under the British flag as the New York and Pacific Steamship Company. By 1913, the company was operating between the west coast of the United States and that of South America. The company purchased the steamship *Santa Cruz* and traded as the Atlantic and Pacific Steamship Company, transporting lumber and passengers. The *Santa Cruz* was the company's first vessel flying the American flag and the first with its trademark green funnel with a white band and a black top. The New York and Pacific Steamship Company merged with the Atlantic and Pacific Steamship Company in 1916 to become the Grace Line Steamship Company, specializing in service to South America's west coast and later expanding to the Caribbean as a U.S.-flagged steamship company.⁴

Grace Line continued regular service between the United States and South America through the 1950s. During that time, combination cargo/passenger ships were popular, and Grace Line acquired nine ships, six of which came from the government. Grace outfitted six to carry bulk cargo from the United States to South America, including refrigerated holds specifically for bananas. The other three ships serviced the Caribbean and did not carry bananas. In the early

¹ René de la Pedraja, *A Historical Dictionary of the U.S. Merchant Marine and Shipping Industry since the Introduction of Steam* (Westport, CT: Greenwood Press, 1994), 369.

² In the early 1980s, both programs were phased out by the government, but MARAD still had to enforce cargo preferences and other laws affecting merchant shipping. Nancy R. Fox and Lawrence J. White provide an in-depth review of U.S. shipping policies in their article, "U.S. Ocean Shipping Policy: Going Against the Tide," *Annals of the American Academy of Political and Social Science* 553 (September 1997): 75-86.

³ Pedraja, *Historical Dictionary*, 369-370; Brian J. Cudahy, *Box Boats: How Container Ships Changed the World* (New York: Fordham University Press, 2006), 70.

⁴ "Grace Line (W.R. Grace & Co.), New York 1882-1969," at <http://www.theshipslist.com/ships/lines/grace.htm>, accessed 29 September 2008; Alexander G. de Secada, "Arms, Guano, and Shipping: The W.R. Grace Interests in Peru, 1865-1885," *The Business History Review* 59, no. 4 (Winter 1985), 599; Pedraja, *Historical Dictionary*, 226-227.

1960s, Grace Line officials decided to upgrade the fleet with four new vessels called “M” ships. These “combo” ships were efficient and technologically advanced. The new ships were capable of 20 knots, had room for 125 first-class passengers, and could carry a variety of break-bulk cargoes. Grace Line contracted Bethlehem Steel in Sparrows Point, Maryland, to build the four “M” ships, which were part of a class called *Santa Magdalena* that included *Santa Magdalena*, *Santa Mariana*, *Santa Maria*, and *Santa Mercedes*, whose name was later changed to *Patriot State*.⁵

CONSTRUCTION

George G. Sharp Company, a naval architecture and engineering firm, did an in-depth study prior to designing the *Santa Magdalena* class for Grace Line. The company analyzed the Grace Line’s trade routes in order to produce the most efficient class of vessels and also took into account Grace Line’s need for a design that would reduce cargo-handling time and expenditures. Grace Line’s economists contributed to the study, and, in the end, Sharp’s firm produced a design that was modern, unique, and practical for the commercial services provided by the Grace Line.⁶

Bethlehem Steel of Sparrows Point, Maryland, was awarded the construction contract for the *Santa Magdalena* class. Bethlehem Steel had entered the shipbuilding business in 1904 when it bought Harlan & Hollingsworth in Wilmington, Delaware, and Union Iron Works in San Francisco, California, to form the Bethlehem Steel Corporation Shipbuilding Division. In need of a yard, Bethlehem Steel bought the Sparrows Point Shipyard in 1917. The shipyard had been established in the late 1880s by the Maryland Steel Company, and the first vessel from the yard had been delivered in 1891. Bethlehem Steel produced a number of vessels at the shipyard during both world wars. After World War II, the shipyard won some contracts for U.S. Navy vessels, but most of the ships built were for the commercial sector and ranged from barges to large seagoing ships. The maritime industry regarded the yards of Bethlehem Steel as one of the top producers of ships in the United States.⁷

An economic downturn in the 1980s slowed the production of ships at Bethlehem’s Sparrows Point yard. By 1986, construction of large ships had ceased at Sparrows Point; instead, the company focused on repairing ships and building ocean barges. The company utilized a graving dock (1,200' x 200') capable of dry-docking vessels up to 300,000 tons deadweight and a floating dry dock able to lift ships up to 40,000 tons. In 1997, Bethlehem sold Sparrows Point to Veritas Capital, and the yard was renamed Baltimore Marine Industries. The company did not prosper

⁵ “Grace Line (W.R. Grace & Co.), New York 1882-1969.”

⁶ “History of T.S. Patriot State,” available at <http://weh.maritime.edu/campus/tsps/history.html>, accessed 21 August 2008.

⁷ “Bethlehem Steel Company, Wilmington, DE,” available at <http://www.shipbuildinghistory.com/history/shipyards/2large/inactive/bethwilmington.htm>, accessed 7 September 2008; “Bethlehem Steel Company, Sparrows Point, MD,” available at <http://shipbuildinghistory.com/history/shipyards/1major/inactive/bethsparrowspoint.htm>, accessed 7 September 2008; Frederic C. Lane, *Ships for Victory: A History of Shipbuilding under the U.S. Maritime Commission in World War II* (Baltimore, MD: Johns Hopkins Press, 1951), 33, 37.

and filed for bankruptcy in June 2003. Another company bought the property to dismantle MARAD ships, but its attempt was short-lived. The yard is presently inactive.⁸

DESIGN & ENGINEERING FEATURES

The design of the *Santa Magdalena* class allowed the ships to carry a high cubic capacity of freight. There were five holds, three of which were located forward amidships and two of which were aft. The holds were four decks deep. For southbound voyages from New York, the cargo consisted of a variety of manufactured goods: machinery, rails, steel pipe, and vehicles. There were provisions for bagged or packed cargo to be carried in containers or on pallets. Northbound voyages from South America carried up to 90,000 stems of bananas in refrigerated holds, containers carrying around 200,000 cubic feet of cargo, 1,500 tons of liquid cargo, and vehicles. Sharp's firm installed conveyors and elevators to carry the bananas and cargo into holds 1, 3, and 4, which resulted in decreased time spent offloading and loading. To expedite the loading of bananas and palletized freight, workers loaded them by hand or by vertical conveyors attached to the side ports. Once aboard, the horizontal conveyors moved the freight across, and elevators lowered it through the decks where it was stowed by hand. Discharging the cargo followed the same procedure as the deck personnel took the cargo to the B deck via an elevator and offloaded it by a conveyor connected to the side port.⁹

With the container revolution taking shape in the early 1960s, Grace Line opted to have container space allocated onboard its ships in holds 2 and 5 and the deck, while holds 3 and 4 carried containers in a single-cell group. Holds 3 and 4 could also carry vehicles. The standard container length was 20', but the ship could carry 40' containers on deck. Total carrying capacity for 20' containers was 175 containers, while placing 40' containers on the deck and 20' containers in the hold reduced the carrying capacity to 147.¹⁰

DESCRIPTION

The *Santa Mercedes* (later *Patriot State*) was of welded steel construction with a raked stem and a modified cruiser stern. The main hull was subdivided into seven transverse bulkheads. As was typical of the class, there were three holds forward of the machinery space and two holds aft. Three decks were located in the hull while the A, promenade, sun, and bridge decks were located in the amidships house, which extended one-third of the ship's length.¹¹

To load and offload the containers, two gantry cranes were located forward of the deckhouse and two aft. The 20-ton "C"-type gantry cranes traveled on rails along the port and starboard sides of

⁸ "Bethlehem Steel Company, Sparrows Point, MD."

⁹ "History of T.S. Patriot State." Sarah Murray includes an interesting chapter on the rise in popularity and consumption of bananas in Chapter 6 of *Movable Feasts: From Ancient Rome to the 21st Century, The Incredible Journeys of the Food We Eat* (New York: St. Martin's Press, 2007).

¹⁰ "Principal Characteristics of T.S. Patriot State," available at <http://weh.maritime.edu/campus/tsp/characteristics.html>, accessed 7 September 2008; Cudahy, *Box Boats*, 68-72; *An Assessment of Maritime Trade and Technology*, U.S. Congress, Office of Technology Assessment, OTA-O-220, (Washington, DC: October 1983), 118.

¹¹ "Principal Characteristics of T.S. Patriot State."

the ship. The cranes were counterbalanced, so deck personnel could marry two cranes together to lift and lower 40' containers or heavy vehicles. In port, the cranes could lift freight and shift it sideways to clear the side of the ship; the operator could then lower the freight directly onto the pier. The whole procedure was accomplished without the aid of dock equipment or personnel.¹²

The machinery room included the essential equipment needed to operate the ship. To achieve the designed speed of 20 knots, the ship had a power plant rated at 19,800 shaft horsepower (shp) to turn a single screw. As was typical of a commercial vessel, there was a single machinery space amidships. Two Babcock and Wilcox D-type boilers generated superheated steam at 905 degrees Fahrenheit, producing 600 psi. Steam pipes fed into a General Electric cross-compound turbine that turned a shaft at 119 rpm. With a capacity of 1,691 tons of fuel oil, the ship had a steaming radius of 8,525 miles. The machinery room also contained the auxiliary equipment required to operate the ship. Three steam-turbine generators created 750 kW of electricity for the ship's power, and one diesel generator rated at 200 kW provided emergency backup power.¹³

The bridge deck in the amidships house contained a number of spaces related to the navigation and safety of the vessel. The wheelhouse was forward and included the helm, engine controls, and modern navigation equipment comprised of Loran, radar, and radio communications. The helm sent electric signals to the steering room where an electric-hydraulic ram turned the rudder. The chartroom was aft of the wheelhouse. The radio equipment room was also on the bridge deck but in a separate space on the port side while the captain's quarters were on the starboard side.¹⁴

Berthing space and amenities for the crew occupied a small section of the ship in the amidships house. The officers berthed in the forward section of the second deck; their staterooms contained private bathrooms. Crew members berthed on the main deck in rooms against the port and starboard sides of the ship with shared bathrooms between the rooms. On the third deck, the officer's mess was in a small room on the starboard side off the galley, while the crew members ate in a small mess located on the port side off the galley.¹⁵

As the *Santa Mercedes*, a majority of the space in the amidships house was reserved for passenger cabins, with berthing space for 125 passengers on the A, sun, and promenade decks. All of the modern rooms were first class with private bathrooms. A tiled swimming pool was located on the A deck with a lounge leading to the outside. The sun deck had a dining area and a bar. In the evening, passengers could watch movies projected on a screen painted on the wall. An elevator in the ship provided access from the main deck to the promenade deck, where an evening lounge was located for passengers to retire for cigars and drinks. The open rooms were spacious and moderately decorated with a casual feeling.¹⁶

¹² "Principal Characteristics of T.S. Patriot State."

¹³ "Principal Characteristics of T.S. Patriot State."

¹⁴ *Record of the American Bureau of Shipping* (New York: American Bureau of Shipping, 1965), 1,222; site visit made by author in September 2008.

¹⁵ Site visit, September 2008.

¹⁶ Site visit, September 2008.

The ship's galley was located on the second deck in the center of the amidships house. The galley contained all the modern appliances needed to prepare meals for the crew and passengers. The bakery, butcher shop, and vegetable preparation space were all located in the galley. Cooks served the crew cafeteria style, while waiters served the passengers. Food was stored in reefers on the second platform, which was accessible by an elevator.¹⁷

OPERATIONAL HISTORY

The *Santa Mercedes* went into service in 1964 just as the container revolution was beginning to take hold. While Grace Line did account for the shift to container shipping within the *Santa Magdalena* class, the company did not make a successful transition. This was evident from 1960 to 1962 in Venezuela when Grace Line failed in negotiations with dockworkers to commit to containerization using *Santa Eliana* and *Santa Leonor*. In mid-1965, the *Santa Mercedes* set sail from New York south to Port-au-Prince, Santa Marta, Cartagena, Cristobal, Balboa, Buenaventura, Guayaquil, and Callao. The voyage lasted twenty-six days, and workers offloaded and loaded freight at the ports of call. In October 1968, the ship sailed from New York, Bermuda, and Charleston to Santa Domingo, Kingston, Cartagena, Panama Canal Zone, Buenaventura, Guayaquil, and Callao.¹⁸

Even as the *Santa Magdalena* class carried cargo, the Grace Company slowly disengaged itself from the business. As early as 1952, J. Peter Grace had begun diversifying the company's portfolio by investing in the chemical industry. By the late 1960s, the Grace Company no longer needed a shipping company. Plus, the currency in Latin America had depreciated. As a result, in 1967, the company decided to sell its shipping assets. Prudential Lines acquired the company two years later, and in 1971, Grace sold its remaining vessels to the Lykes Brothers. Prudential Lines continued service to the west coast of South American under the name Prudential-Grace Lines.¹⁹

Prudential-Grace Lines' sailing schedule in July 1971 included leaving New York and visiting the ports of Port-au-Prince, Santa Domingo, Kingston, and Cartagena, before transiting the Panama Canal Zone and continuing to Buenaventura, Guayaquil, and Callao. In 1973, Prudential-Grace originated in Vancouver and stopped in Seattle, San Francisco, Los Angeles, Balboa, Cristobal, Cartagena, La Guaira, Puerto Cabello, Curaçao, Rio de Janeiro, Santos, Paranagua, Buenos Aires, Straits of Magellan, Valparaiso, Callao, and Guayaquil. In 1977, Prudential sold off its Grace Line holdings to Delta Line. Shortly after the acquisition, the Delta Line replaced the *Santa Magdalena* class. The company had suffered economic losses from the operation of the LASH vessels (Lighter Aboard Ships, which used a system of barges carried on board a lighter ship), and it decided to purchase Prudential Line and combine the two businesses' services to South America. In 1978, the Delta Line failed to turn a profit and brought in Andrew

¹⁷ Site visit, September 2008.

¹⁸ "Prudential Grace Lines," in "Maritime Timetable Images," available at <http://www.timetableimages.com/maritime/images/grace.htm>, accessed 2008.

¹⁹ Alex Roland, W. Jeffrey Bolster, and Alexander Keyssar, *The Way of the Ship: America's Maritime History Reenvisioned, 1600-2000* (Hoboken, NJ: John Wiley and Sons, 2008), 351, 363; Pedraja, *Historical Dictionary*, 228-229.

Gibson, who had previously directed the Maritime Administration. One of his priorities was to convert the old freight fleet into container ships, and this resulted in the sale of the *Santa Magdalena* class to the Maritime Administration.²⁰

In spring 1984, the Massachusetts Maritime Academy obtained the *Santa Mercedes* from the Maritime Administration for use as a training ship and renamed it the *Patriot State*.²¹ The State of Massachusetts formed the Massachusetts Nautical Training School in 1891 to train young men for employment in the U.S. Merchant Marine. The school changed its name in 1942 to the Massachusetts Maritime Academy and moved to Buzzards Bay in 1949. The conversion of the *Patriot State* for use as a training ship was undertaken in two phases. The activation phase occurred at the Triple A Shipyard in San Francisco, California. Afterwards, tugs towed it to the Bender Shipyard in Mobile, Alabama, for alterations. The shipyard removed the inside and outside cargo-handling gear and installed a berthing area in hold 3. In 1986, cadets further modified hold 4 to include a machine shop, maintenance-training labs, classrooms, a spare parts storage area, and a gym. The *Patriot State* embarked on a new career as a training vessel in winter 1986.²²

In 1993, further modifications were made to the ship. The school upgraded the berthing arrangement on the D deck of hold 3 by installing heads, showers, lockers, and bunks. The academy finished the upgrades in 1997, and additional modifications were made to the C deck and B deck areas. The upgrades allowed the vessel to carry 698 passengers, made up of fifty crew members and 648 cadets and faculty. Additionally, the school installed control-desuperheaters in the boilers to produce more steam, thereby accelerating the ship's speed without exceeding the boiler's temperature limits.²³

The Massachusetts Maritime Academy normally ran its training cruises for the cadets in the winter. On average, the *Patriot State* was underway for sixty days providing educational training and practical experience for the cadets, but there were ports of call along the way. In 1992, for example, the *Patriot State* embarked on a cruise commemorating Christopher Columbus' 1492 voyage with the first port of call at Genoa, Italy. The stage/jazz band provided entertainment for one night in each port, playing outside on the promenade as well as during dinner. Afterwards, the band would crank up the music and play cover music while the officers danced.²⁴ In general, the cadets led a Spartan life aboard the vessel, and it was crowded with the entire school and faculty. A favorite spot on the ship was the "steel beach" where cadets would sunbathe forward

²⁰ "Prudential Grace Lines"; Pedraja, *Historical Dictionary*, 172, 499.

²¹ The federal government had been providing training ships to states that established nautical schools since 1874. By 1962, New York, Pennsylvania, Massachusetts, California, Maine, and Texas had established schools.

²² "History of T.S. Patriot State"; René de la Pedraja, "State Maritime Academies, 1874-present," in *A Historical Dictionary of the U.S. Merchant Marine and Shipping Industry Since the Introduction of Steam* (Westport, CT: Greenwood Press, 1994), 581-586; Robert T. McLaren, "School Ships of the Maritime Academies," *Sea Classics* (November 2005).

²³ "History of T.S. Patriot State."

²⁴ Peter Botelho, Massachusetts Maritime Academy alumnus, personal communication with author, September 2008.

of the amidship house. Other cadets enjoyed the gym on D deck in hold 4, where weightlifting was particularly popular.²⁵

The *Patriot State* returned to the Maritime Administration in 1999 after thirteen years of service as a school training ship when the Massachusetts Maritime Academy determined that the ship's upkeep required more funds than were available. The Maritime Administration berthed the vessel in the James River Reserve Fleet. It is currently awaiting disposal, but the design layout attracted the attention of military officials who thought the ship would make a good training platform for special counterterrorism units. Simulated terrorist attacks took place on the ship, giving military personnel the opportunity to practice close quarters combat. Evidence of their practice was quite noticeable in a 2008 site visit due to the large number of shell casings and torn targets scattered throughout the ship.²⁶

CONCLUSION

The *Patriot State* is significant as an example of a bold new design ordered by and built for the Grace Line shipping company. The vessel's plan incorporated the latest technologies to carry bulk cargo and passengers from the United States to South America and back. It had a short, but productive, career, but its design ultimately did not meet the changing trends of the market, and the ship was eventually returned to the Maritime Administration's mothball fleet. The ship then served as a training vessel by the Massachusetts Maritime Academy until the Maritime Administration resumed authority over it in 1999 and moved it to the National Defense Reserve Fleet where it awaits scrapping.

²⁵ "History of T.S. Patriot State"; Brian Seuter, Massachusetts Maritime Academy alumnus, Class of 1990, personal communication with author, 2008.

²⁶ Site visit, September 2008.

BIBLIOGRAPHY

Books

An Assessment of Maritime Trials and Technology. Washington, DC: U.S. Congress, Office of Technology Assessment, OTA-O-220, October 1983.

Cudahy, Brian J. *Box Boats: How Container Ships Changed the World*. New York: Fordham University Press, 2006.

Lane, Frederick C. *Ships for Victory: A History of Shipbuilding under the U.S. Maritime Commission in World War II*. Baltimore: Johns Hopkins Press, 1951.

Murray, Sarah. *Movable Feasts: From Ancient Rome to the 21st Century, The Incredible Journeys of the Food We Eat*. New York: St. Martin's Press, 2007.

Pedraja, René de la. *A Historical Dictionary of the U.S. Merchant Marine and Shipping Industry Since the Introduction of Steam*. Westport, CT: Greenwood Press, 1994.

_____. *Oil and Coffee: Latin American Merchant Shipping from the Imperial Era to the 1950s*. Westport, CT: Greenwood Press, 1998.

Record of the American Bureau of Shipping. New York: American Bureau of Shipping, 1965.

Roland, Alex, W. Jeffrey Bolster, and Alexander Keyssar. *The Way of the Ship: America's Maritime History Reenvisioned, 1600-2000*. Hoboken, NJ: John Wiley and Sons, 2008.

Wealleans, Anne. *Designing Lines: A History of Interior Design Afloat*. New York: Routledge, 2006.

Whitehurst, Clinton H. *The U.S. Merchant Marine: In Search of an Enduring Maritime Policy*. Annapolis, MD: Naval Institute Press, 1983.

Articles

de Secada, Alexander G. "Arms, Guano, and Shipping: The W.R. Grace Interests in Peru, 1865-1885." *The Business History Review* 59, no. 4 (Winter 1985): 597-621.

Hutchins, John G. B. "The American Shipping Industry Since 1914." *The Business History Review* 28 (June 1954): 105-127.

Internet Material

"Bethlehem Steel Company, Wilmington, DE." Available at <http://www.shipbuildinghistory.com/history/shipyards/2large/inactive/bethwilmington.htm>, accessed 7 September 2008.

“Bethlehem Steel Company, Sparrows Point, MD.” Available at <http://shipbuildinghistory.com/history/shipyards/1major/inactive/bethsparrowspoint.htm>, accessed 7 September 2008.

Grace Line advertisement, Item T2649, Duke University Libraries Digital Collection. Available at <http://library.duke.edu/digitalcollections/adaccess.T2649/pg.1/>, accessed September 2008.

“Grace Line (W.R. Grace & Co.), New York 1882-1969.” Available at <http://www.theshipslist.com/ships/lines/grace.htm>, accessed 29 September 2008.

“History of T.S. Patriot State.” Available at <http://weh.maritime.edu/campus/tsps/history.html>, accessed 21 August 2008.

“Principal Characteristics of T.S. Patriot State.” Available at <http://weh.maritime.edu/campus/tsps/characteristics.html>, accessed September 2008.

“Prudential Grace Lines,” in “Maritime Timetable Images.” Available at <http://www.timetableimages.com/maritime/images/grace.htm>, accessed 2008. This site includes Grace Line and Prudential-Grace Line advertising pamphlets.

APPENDIX

The following images were scanned from a booklet of plans located in the Library at the Maine Maritime Academy. The images were drawn by P.J. Watson in 1992. The images are printed with the permission of the Maine Maritime Academy.

INDEX

PROFILES

HOUSE PRINTS

FOS'L & 1 HOLD PRINTS

2 HOLD PRINTS

3 HOLD PRINTS

ENGINE ROOM PRINTS

4 HOLD PRINTS

FANTRAIL & 5 HOLD PRINTS

STATISTICS

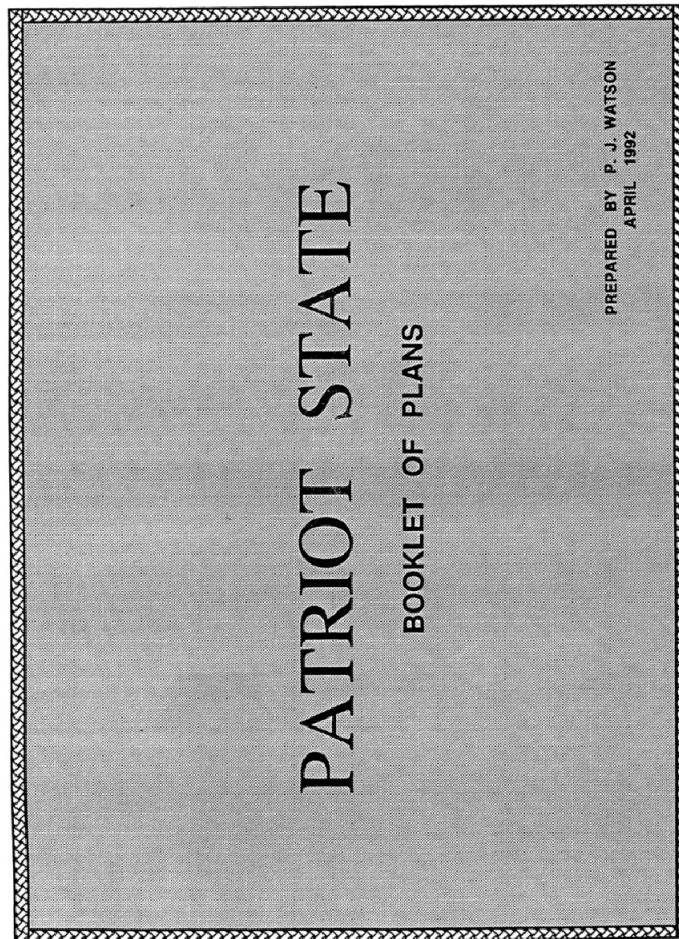
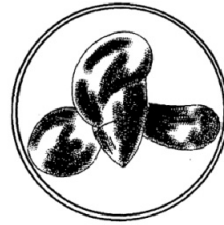

BOOKLET OF PLANS

PROFILE PRINTS

PROFILE ABOVE THE WATERLINE

STARBOARD PROFILE

PORT PROFILE

INBOARD PROFILE

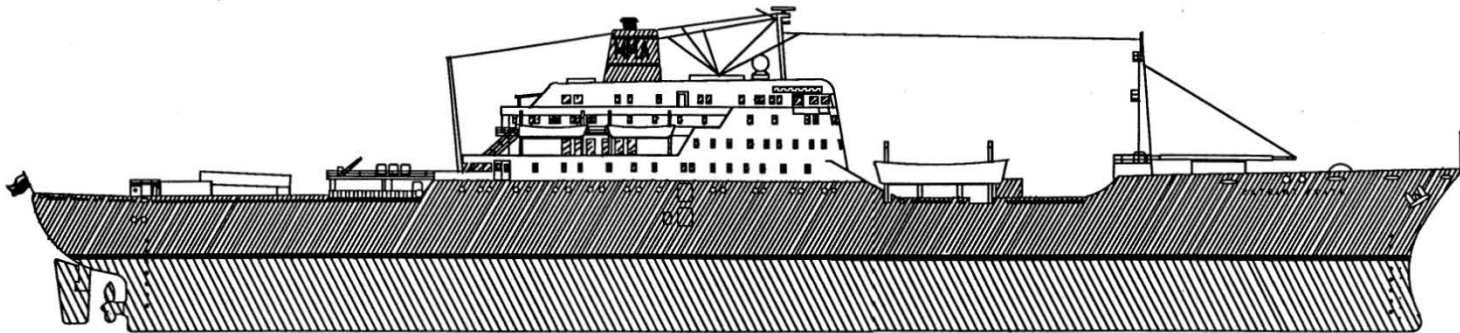

PATRIOT STATE

PATRIOT STATE
BUILT: Bethlehem Steel Company, Sparrows Point, Md.
NAMED: SANTA MERCEDES
LENGTH: 508' 6" BEAM: 79' DRAFT: 26'
18,000 SHIP @ 115 RPM, PROPELLER PITCH 18' 10.5"

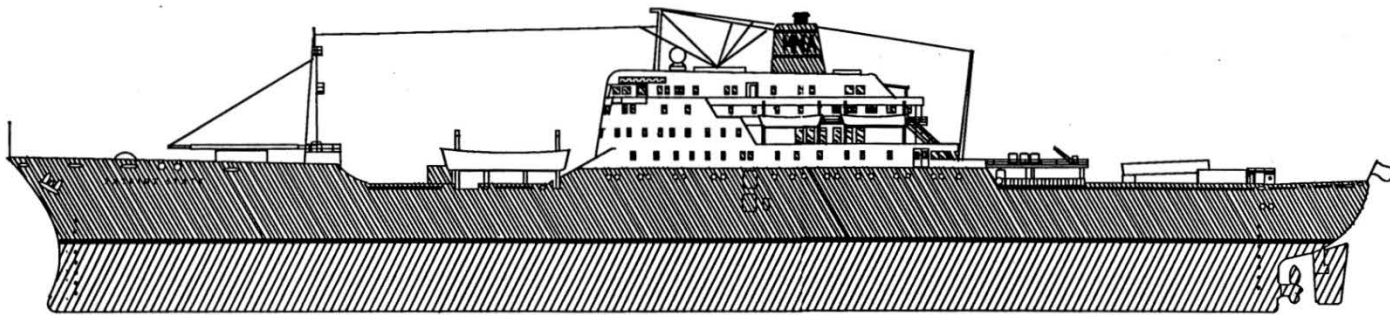

PATRIOT STATE

PATRIOT STATE
BUILT: Bethlehem Steel Company, Sparrows Point, Md.
NAMED: SANTA MERCEDES
LENGTH: 508' 6" BEAM: 79' DRAFT: 26'
18,000 SHP @ 115 RPM, PROPELLER PITCH 18' 10.5"

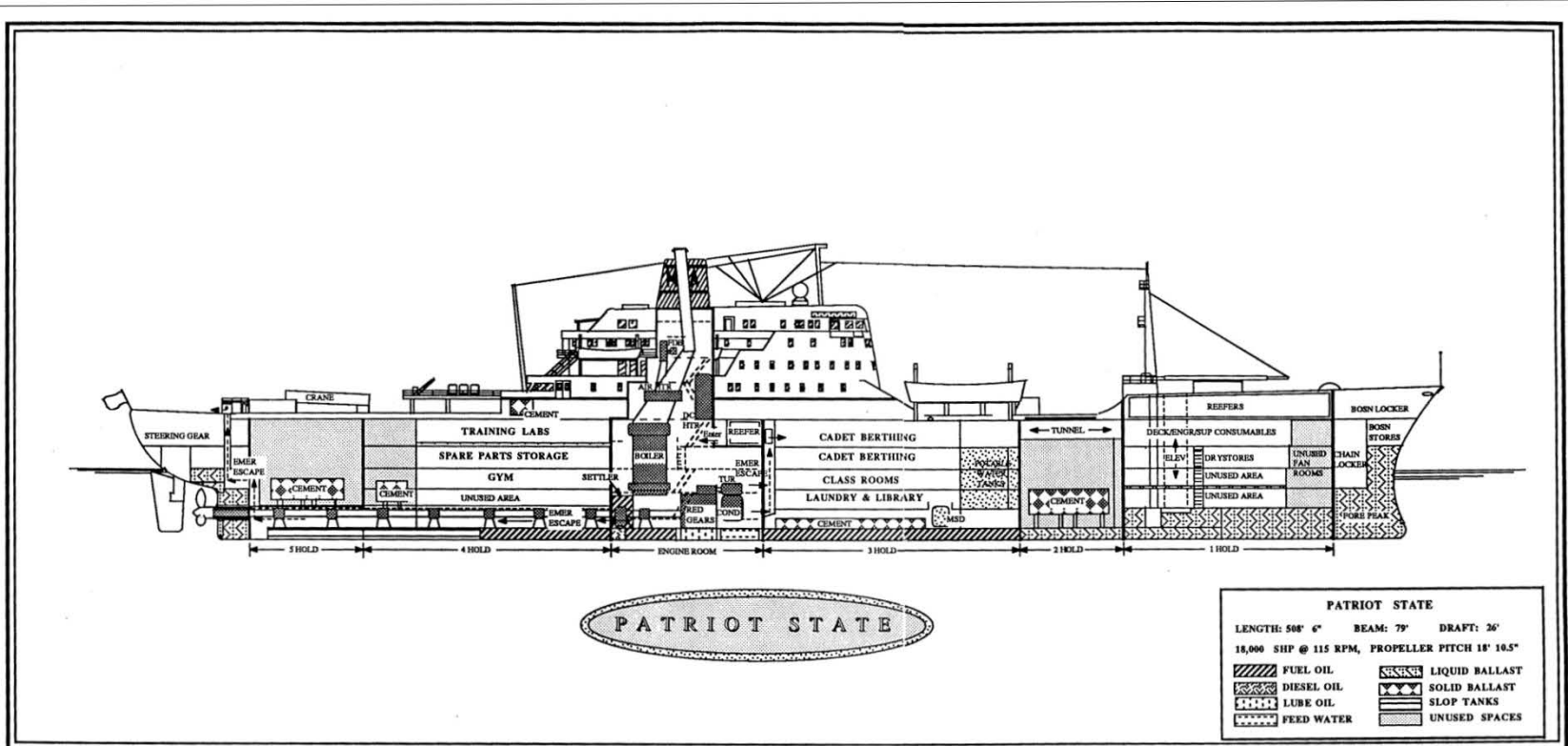

BOOKLET OF PLANS

HOUSE PRINTS

TOP OF THE HOUSE

BRIDGE DECK

SUN DECK

PROMENADE DECK

A DECK

MAIN DECK

B DECK

BRIDGE DECK

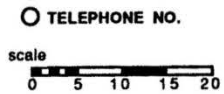
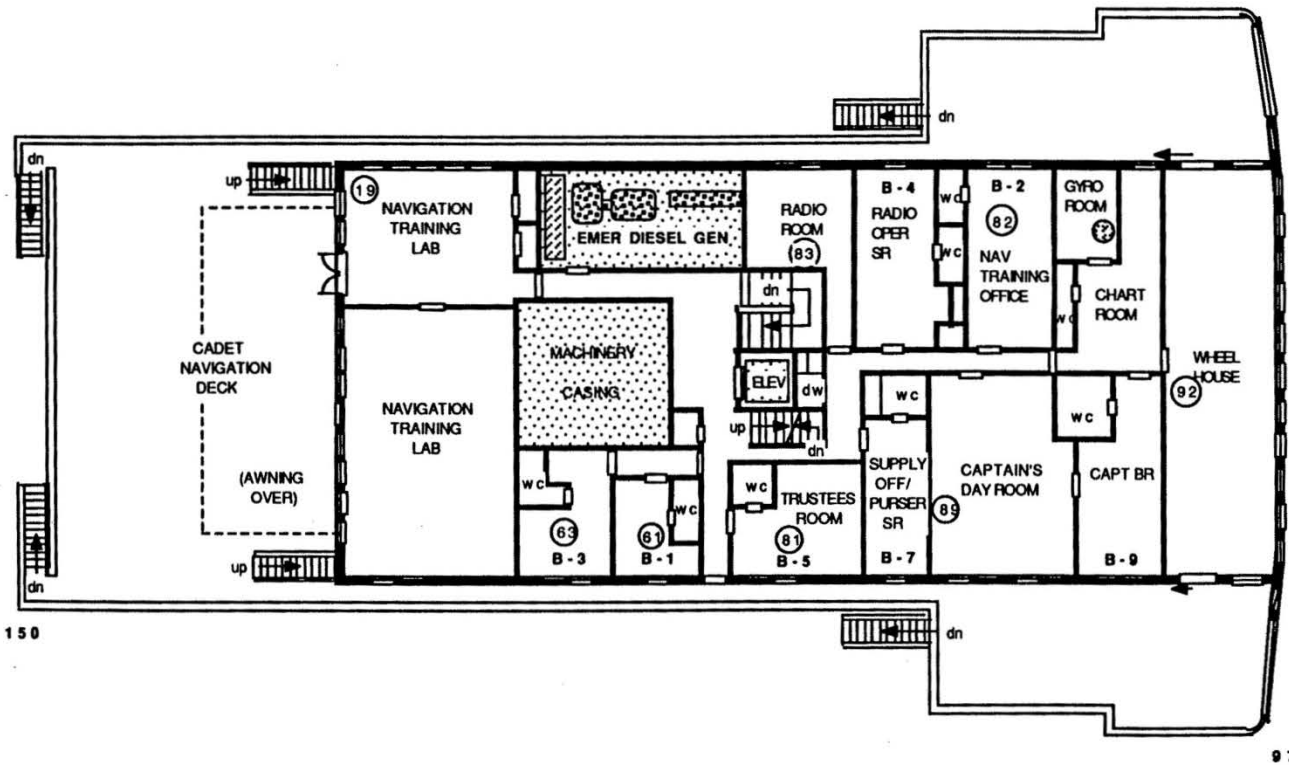

SUN DECK

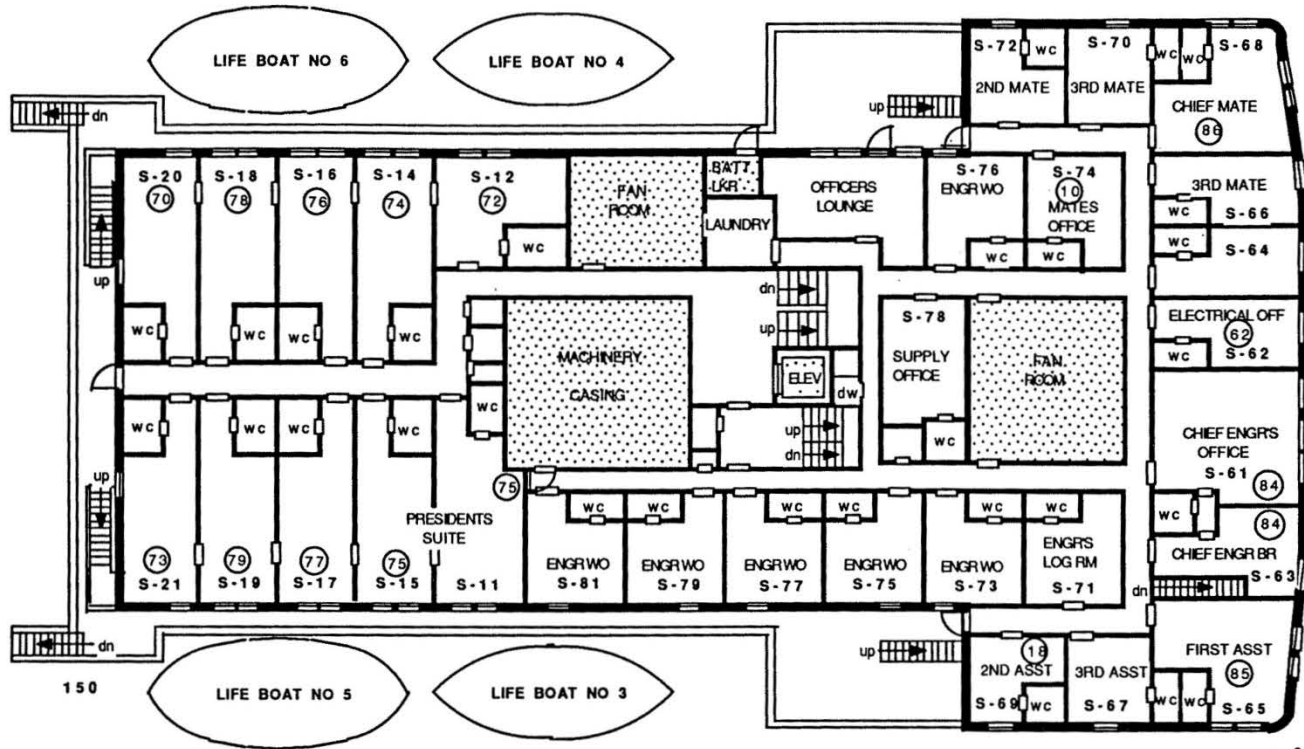

96

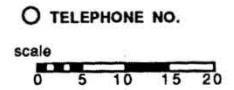

PROM DECK

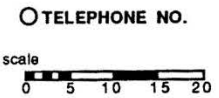
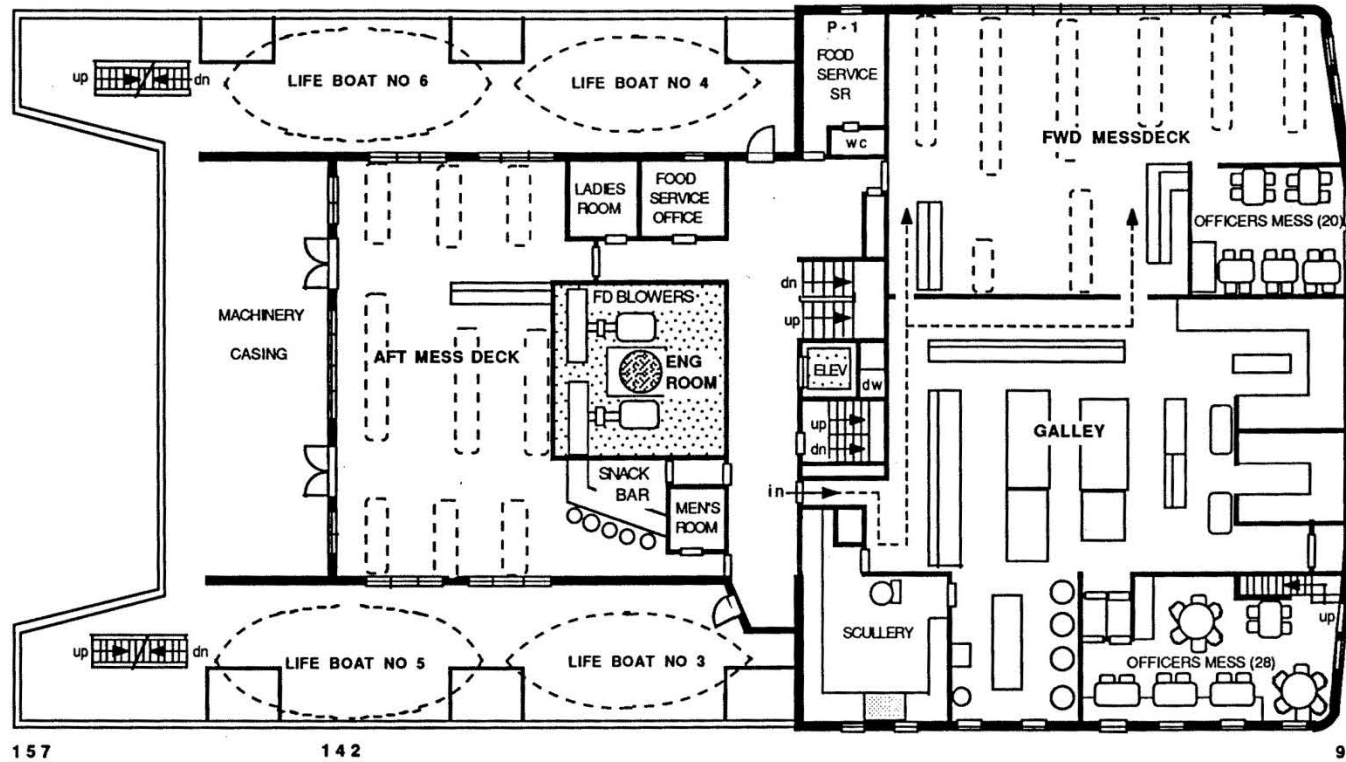

"A" DECK

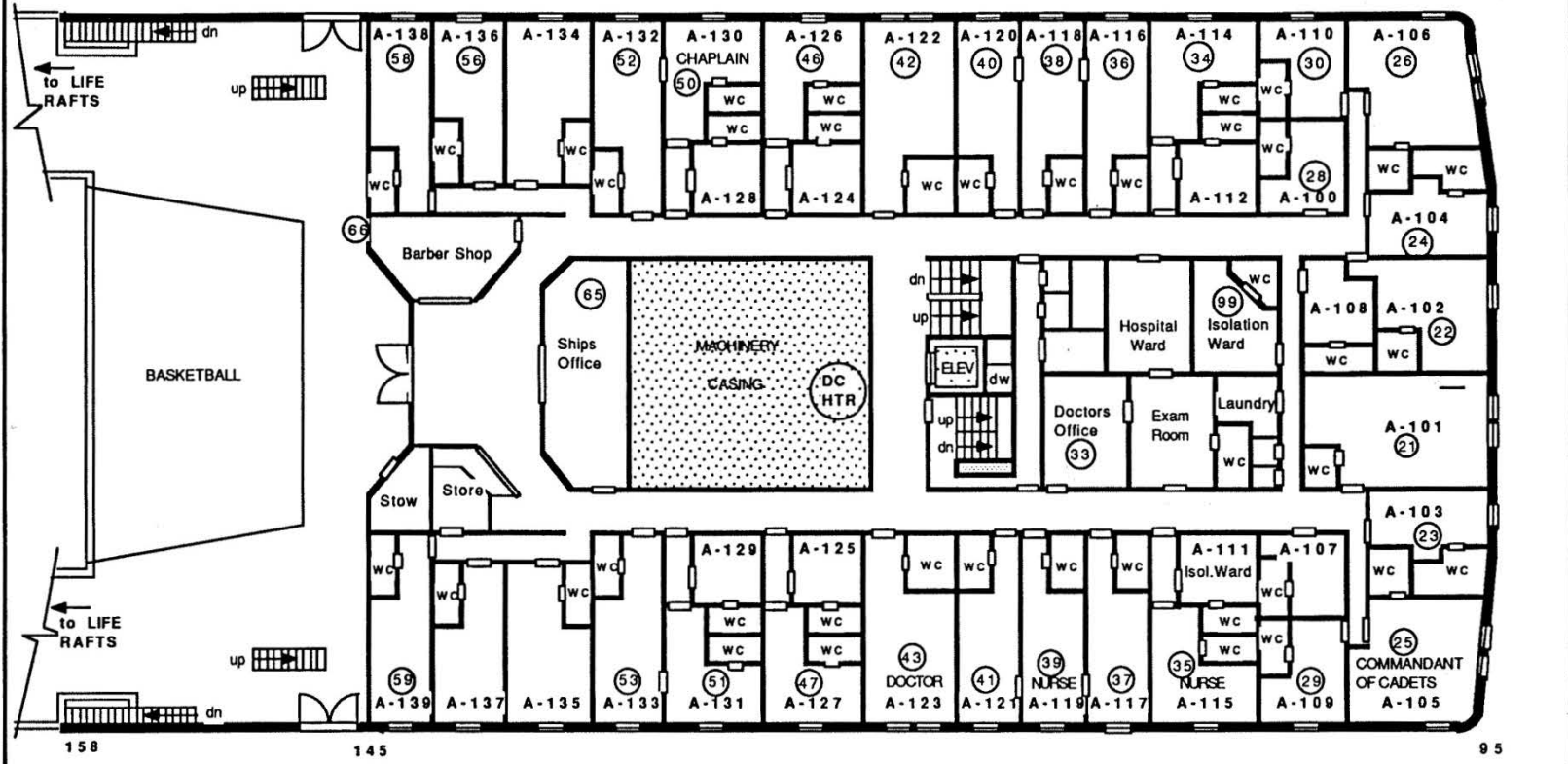

○ TELEPHONE NO.
 scale 0 5 10 15 20

MAIN DECK

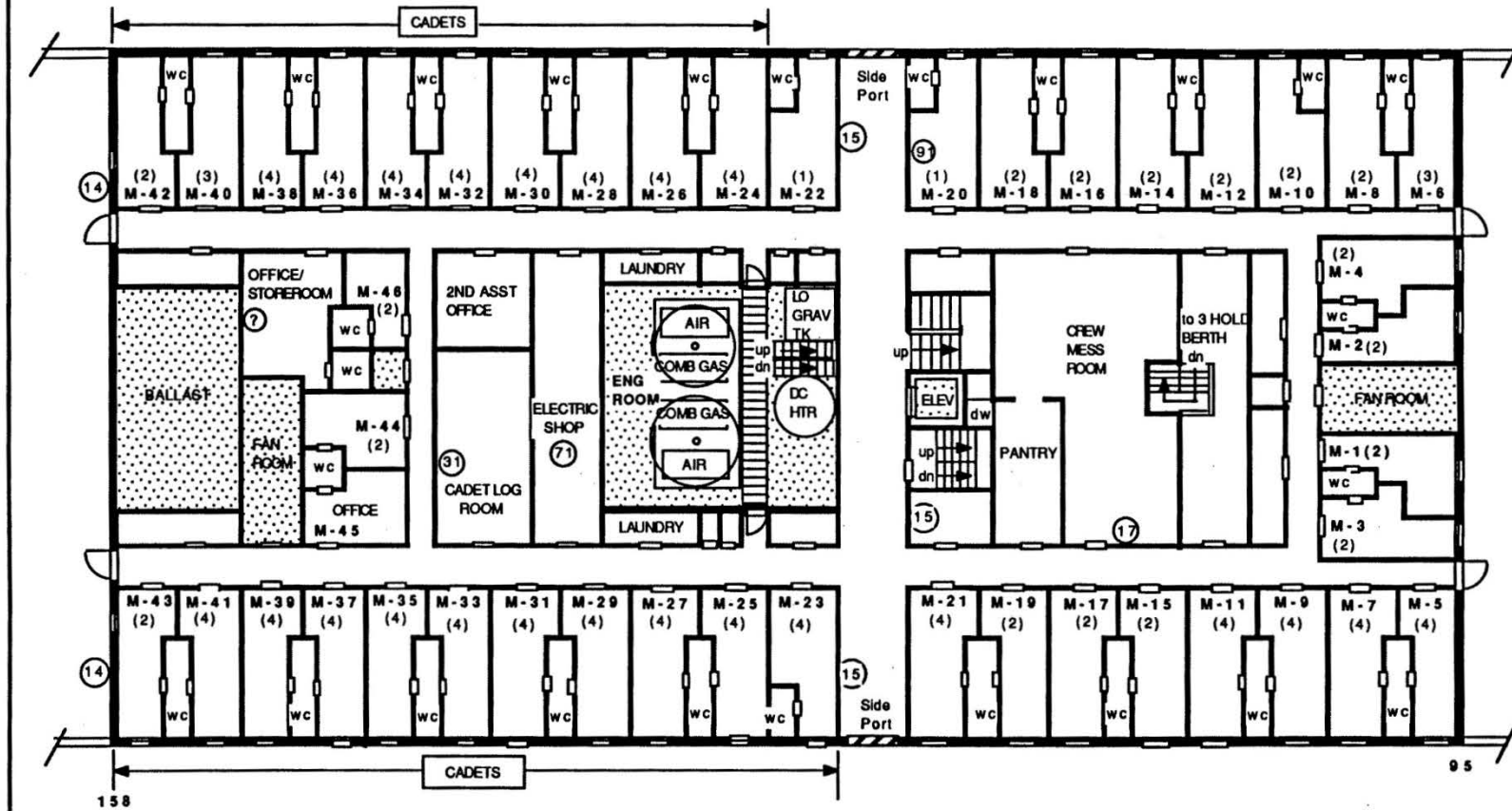

○ TELEPHONE NO.
 scale
 0 5 10 15 20

B DECK

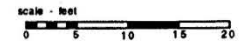
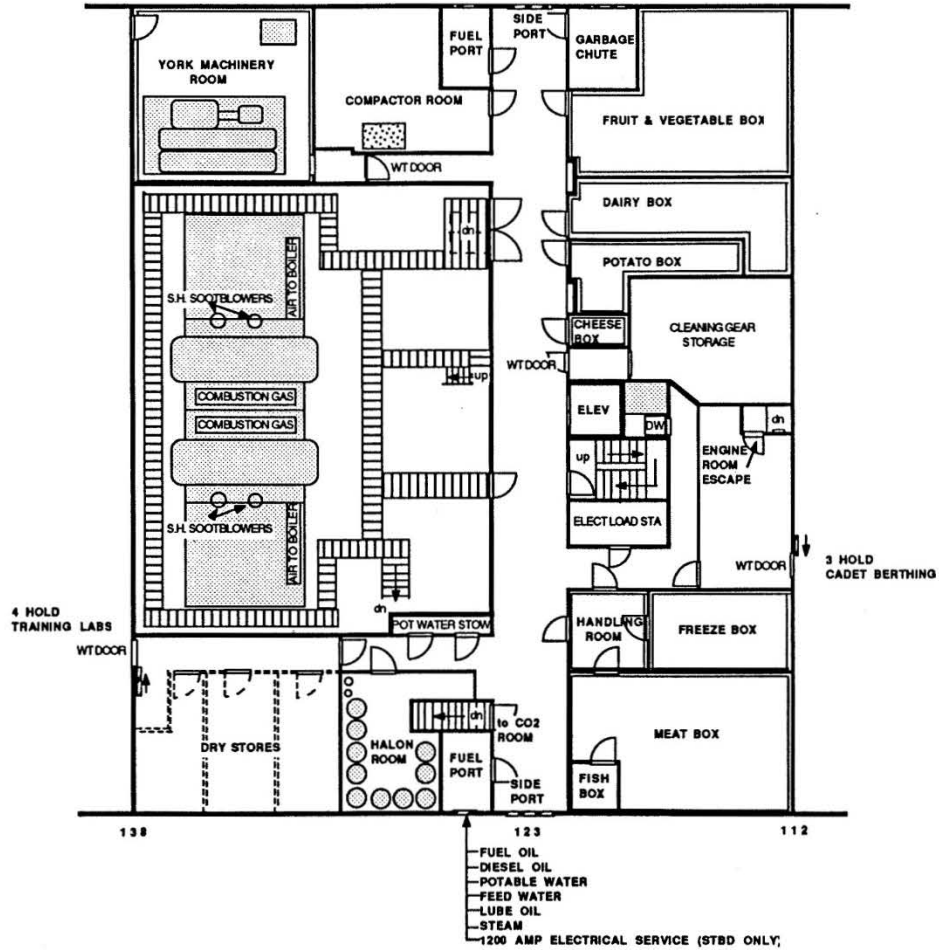

ENCLOSURE (1)

BOOKLET OF PLANS

FOS'L & 1 HOLD PRINTS

FORECASTLE DECK

MAIN DECK

B DECK

C DECK

D DECK

E DECK

TANK TOP DECK

INNERBOTTOM TANKS

1 HOLD / FOS'L DECK

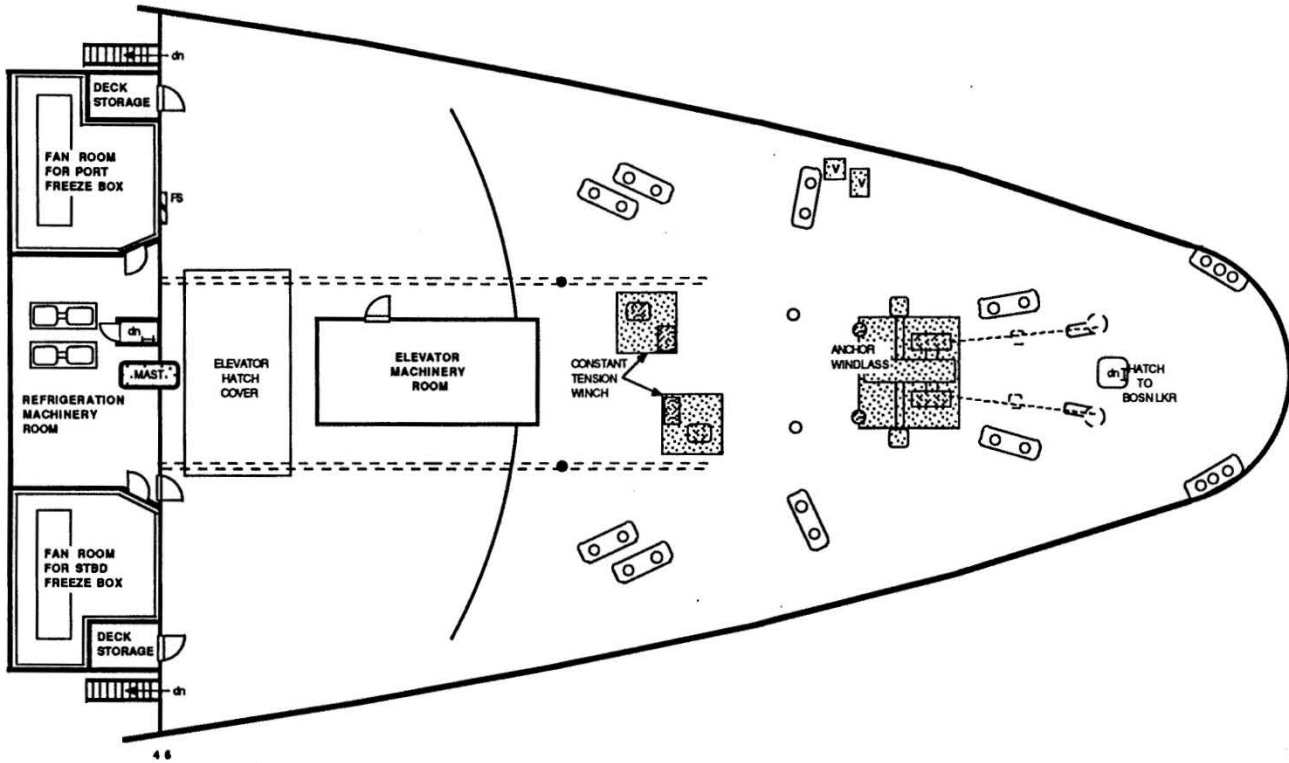

scale - feet
0 5 10 15 20

1 HOLD / MAIN DECK

REFRIGERATED STORES

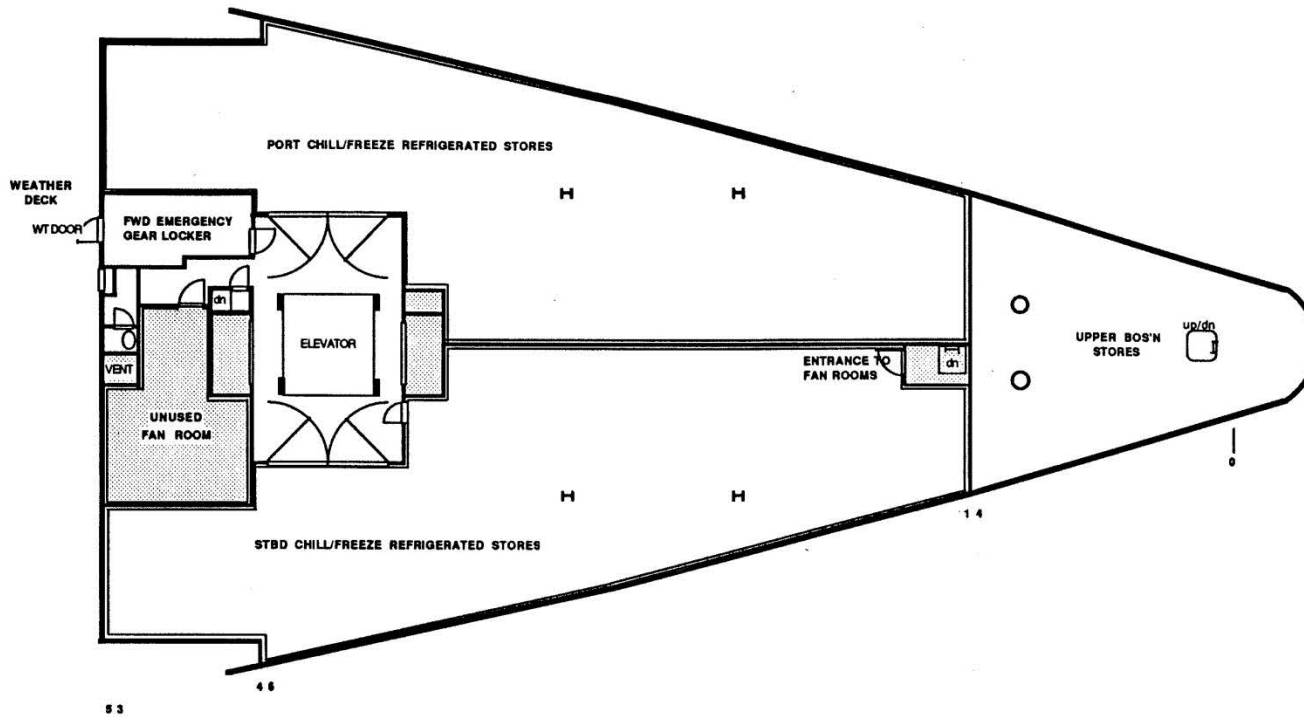

UNUSED AREA

scale - foot
0 5 10 15 20

1 HOLD / B DECK

SHIPS STORES

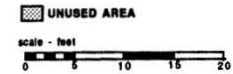
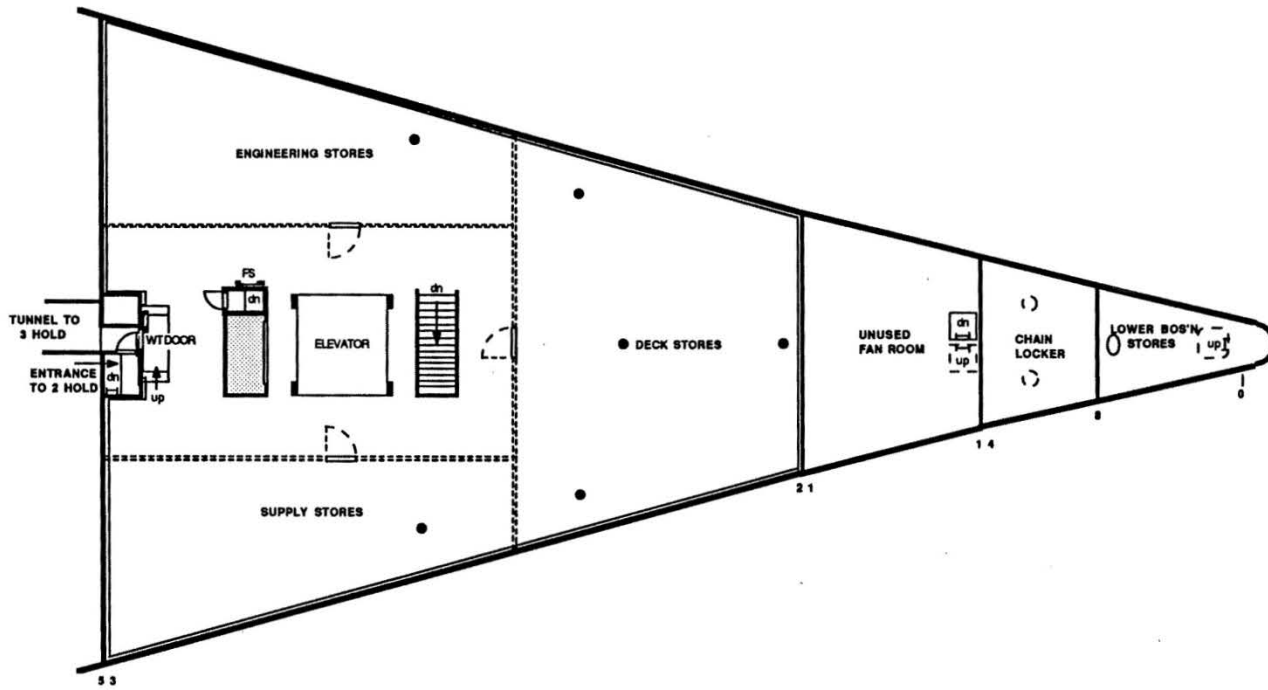

1 HOLD / G DECK

DRY STORES

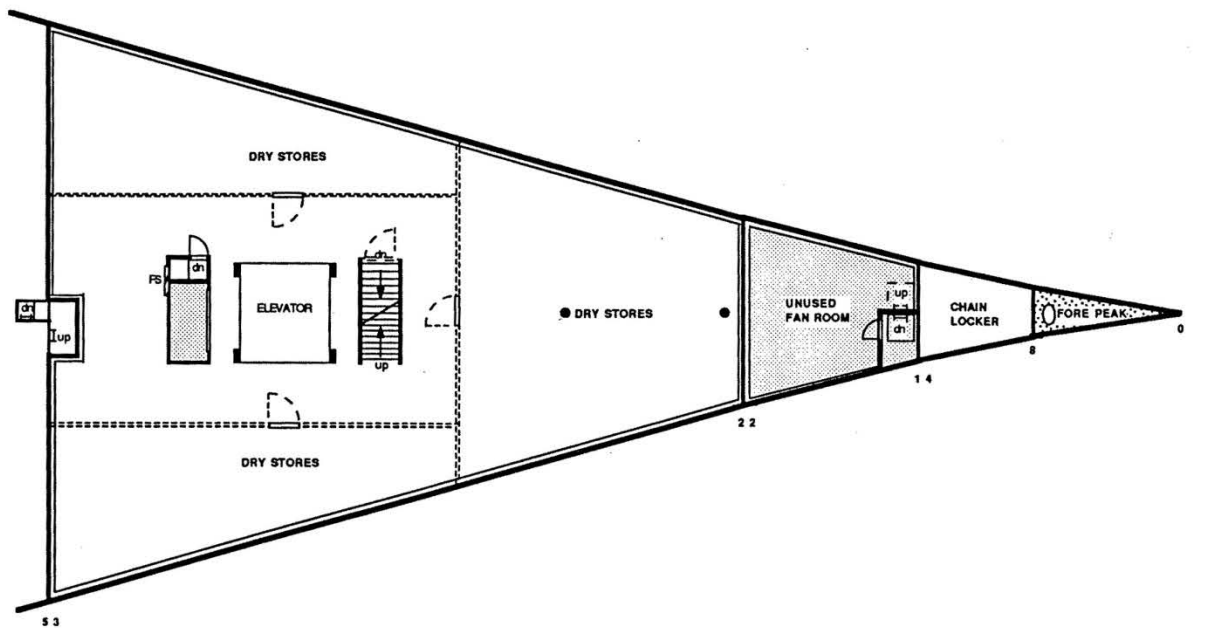

■ BALLAST WATER
■ UNUSED AREA

scale - feet
0 5 10 15 20

1 HOLD / D DECK

UNUSED AREA

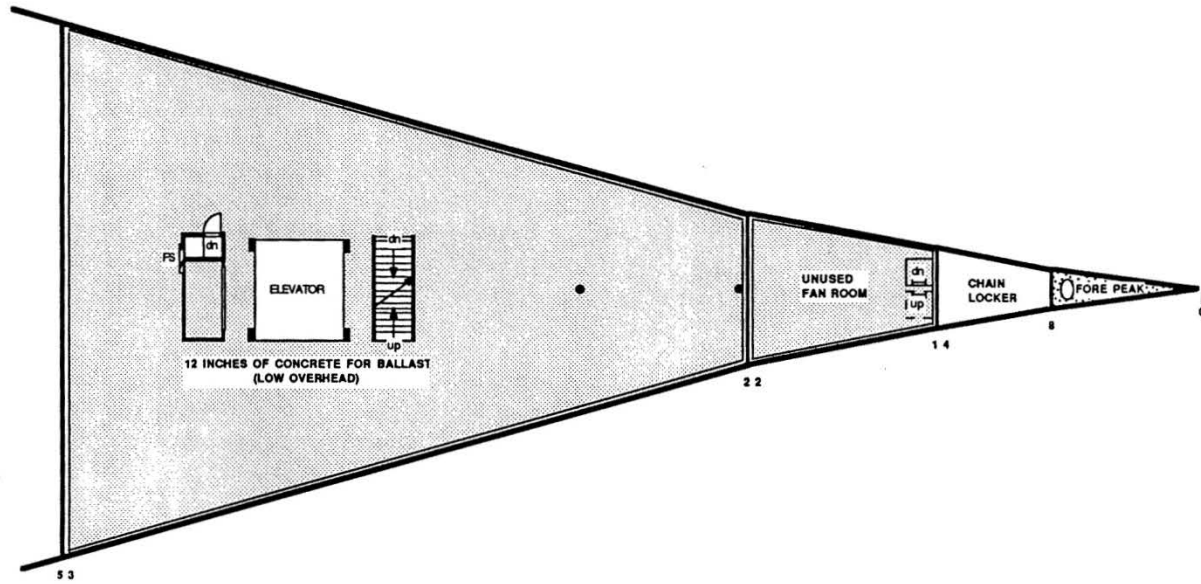

12 INCHES OF CONCRETE FOR BALLAST (LOW OVERHEAD)

ELEVATOR

UNUSED FAN ROOM

CHAIN LOCKER



FORE PEAK

■ BALLAST WATER
■ UNUSED AREA

scale - feet
0 5 10 15 20

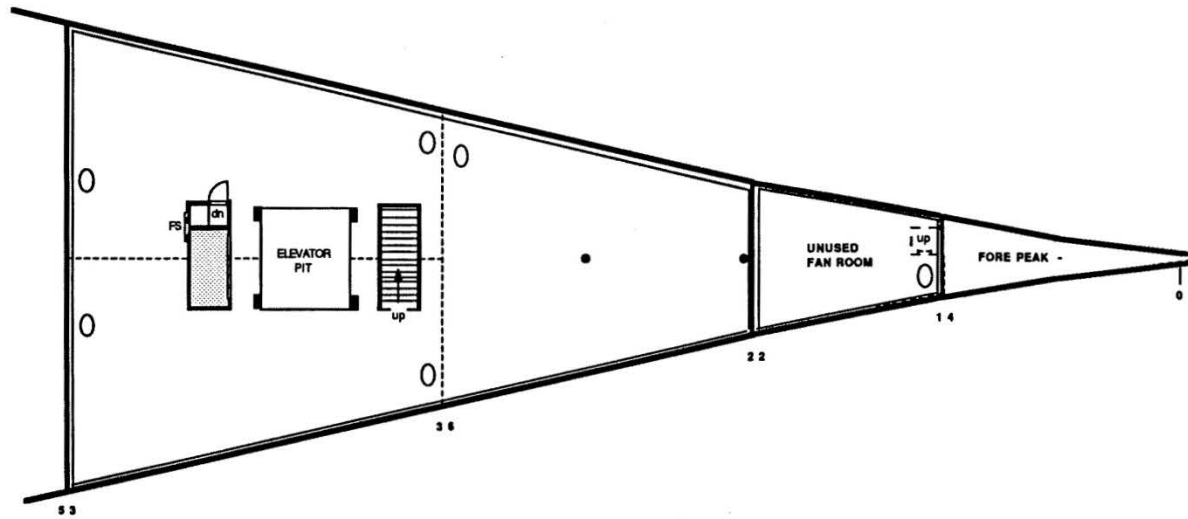
1 HOLD / E DECK



 BALLAST WATER
 UNUSED AREA

scale - feet
0 5 10 15 20

1 HOLD / TANK TOP DECK

DEEP TANKS

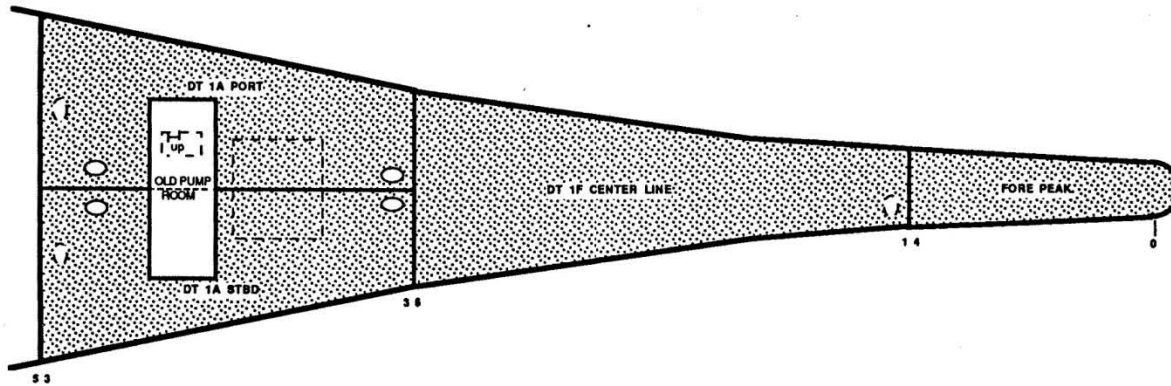

 BALLAST WATER

scale - feet
0 5 10 15 20

1 HOLD / INNERBOTTOM TANKS

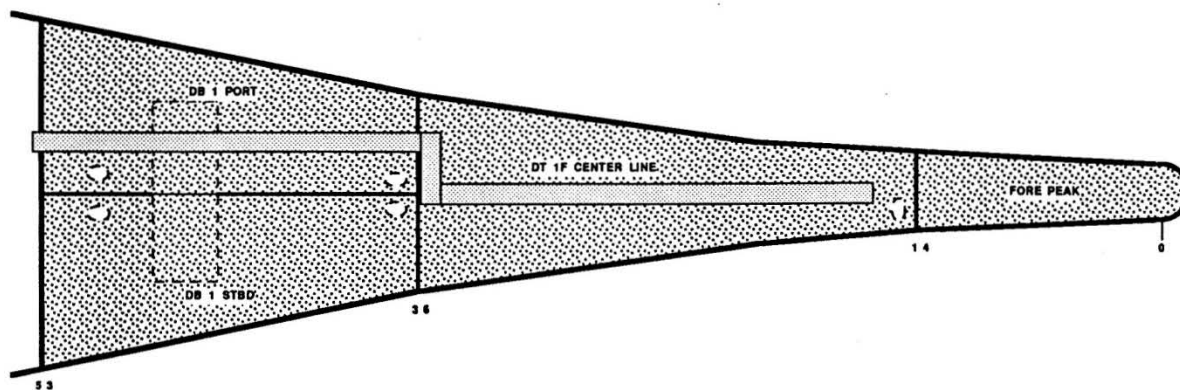

 BALLAST WATER
 PIPE TUNNEL

scale - feet
0 5 10 15 20

BOOKLET OF PLANS

2 HOLD PRINTS

MAIN DECK

B DECK

C DECK

D DECK

E DECK

TANK TOP DECK

INNERBOTTOM TANKS

2 HOLD / MAIN DECK

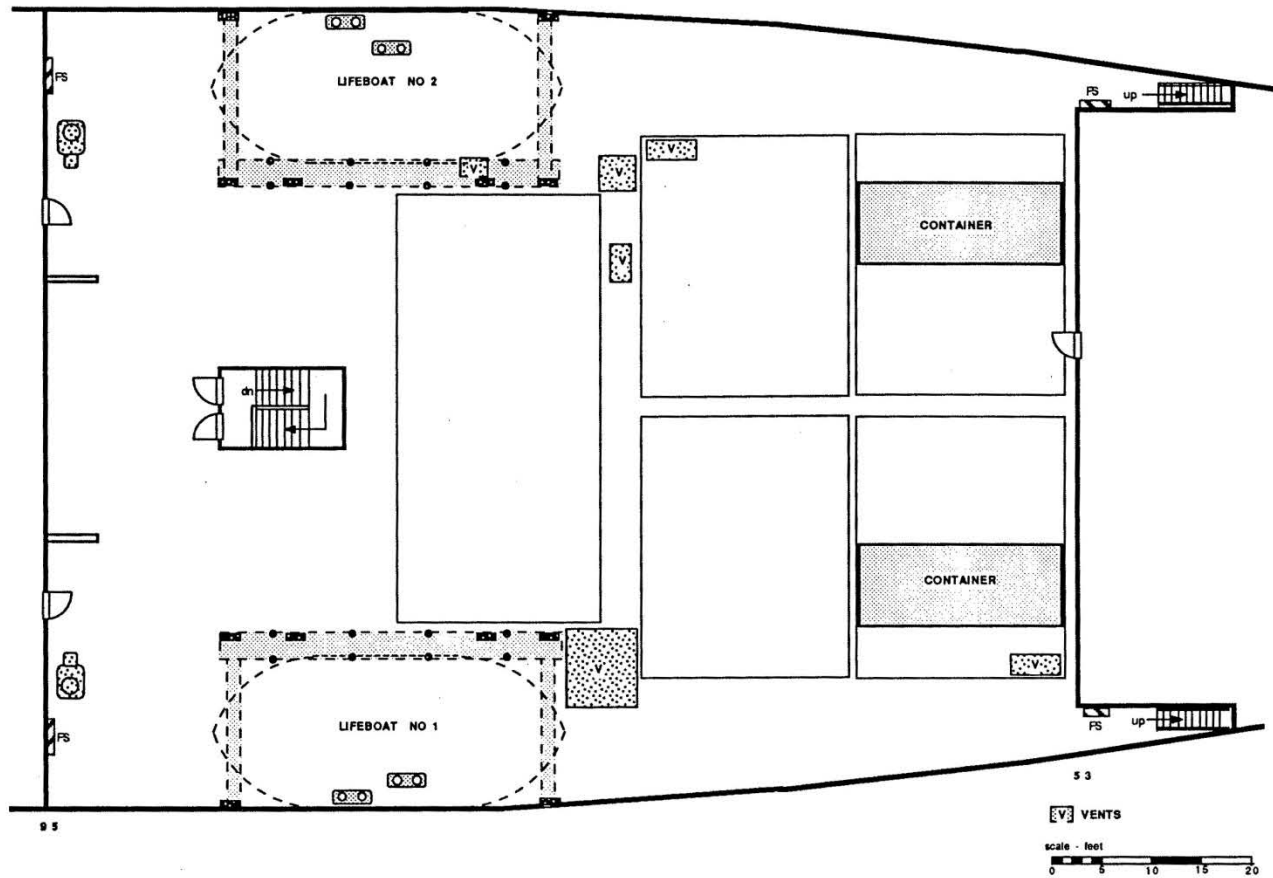

2 HOLD / B DECK

CONTAINER CELL

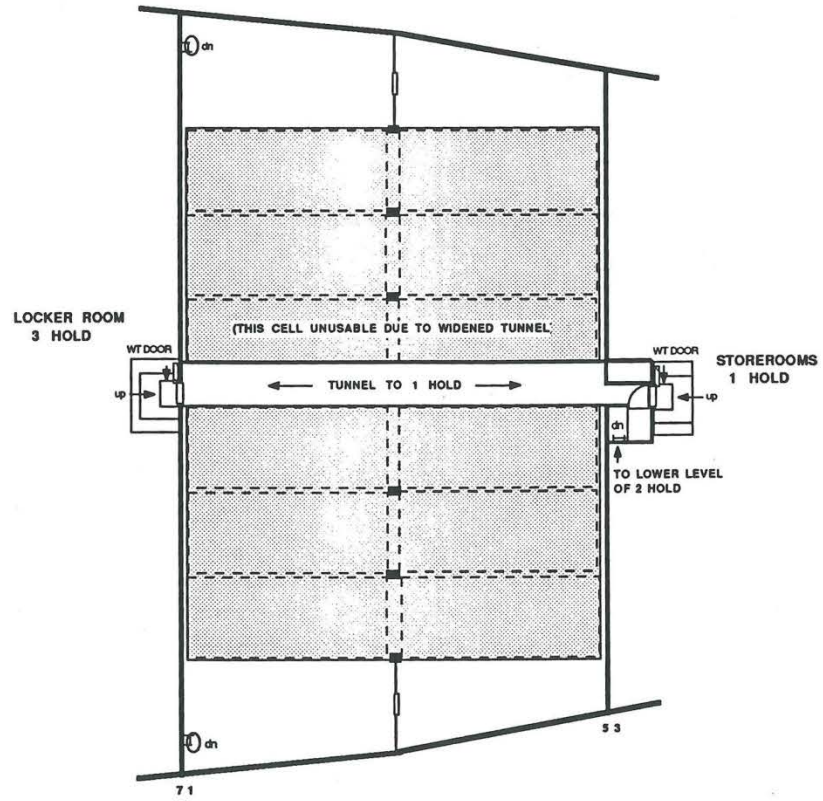

OPEN AREA



2 HOLD / C DECK

CONTAINER CELL

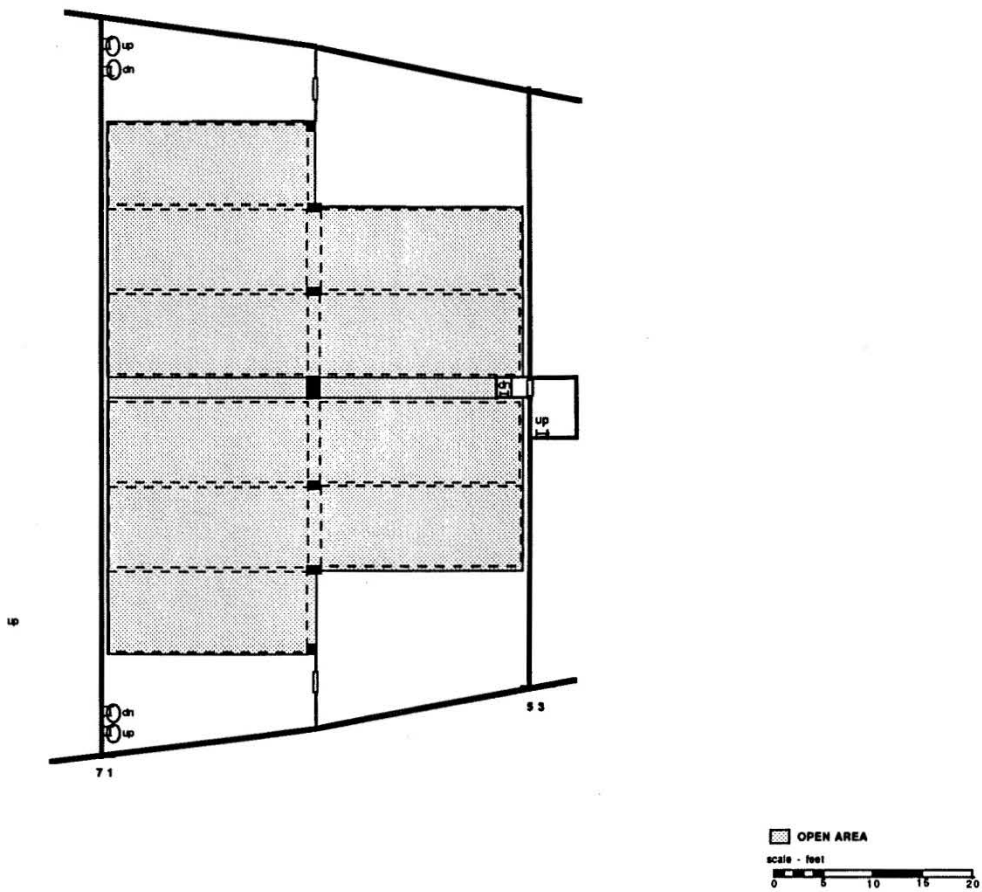

2 HOLD / D DECK

CONTAINER CELL

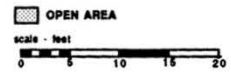
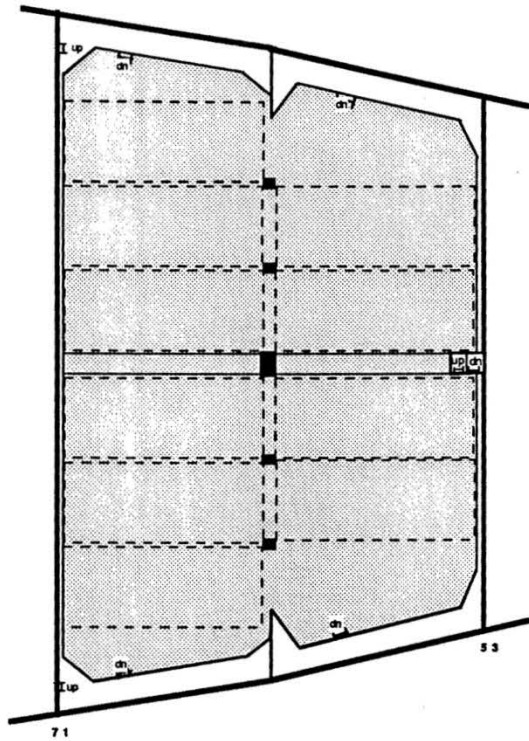

2 HOLD / TANK TOP DECK

CONTAINER CELL

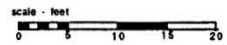
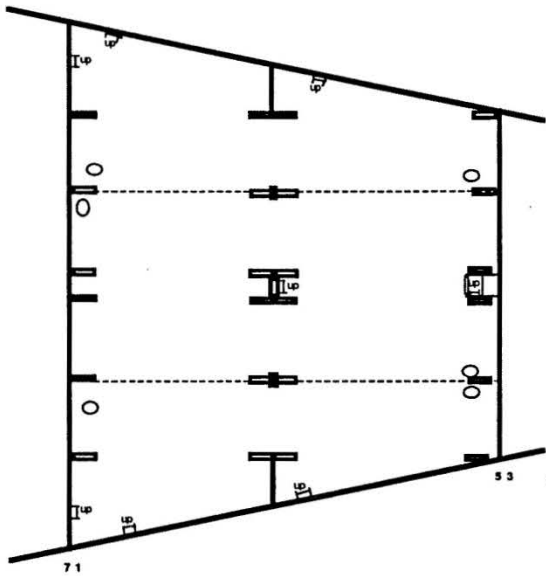

2 HOLD / INNERBOTTOM TANKS

BALLAST TANKS

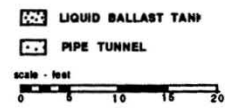
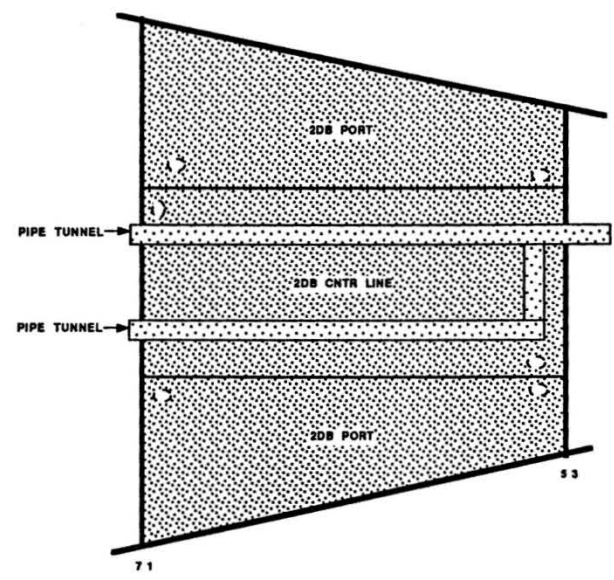

BOOKLET OF PLANS

3 HOLD PRINTS

B DECK

C DECK

D DECK

E DECK

TANK TOP DECK

INNERBOTTOM TANKS

3 HOLD / B DECK

BERTHING

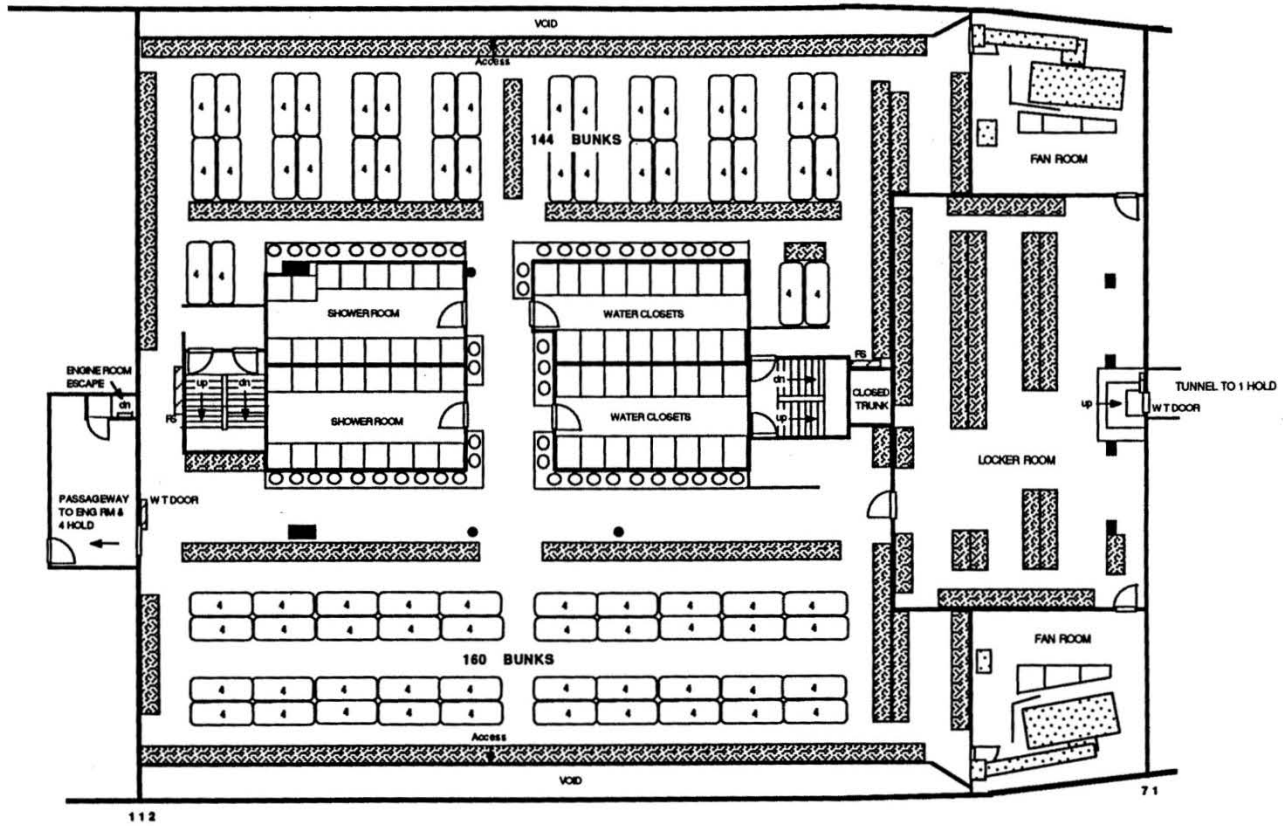

3 HOLD / C DECK

BERTHING AND LOUNGE

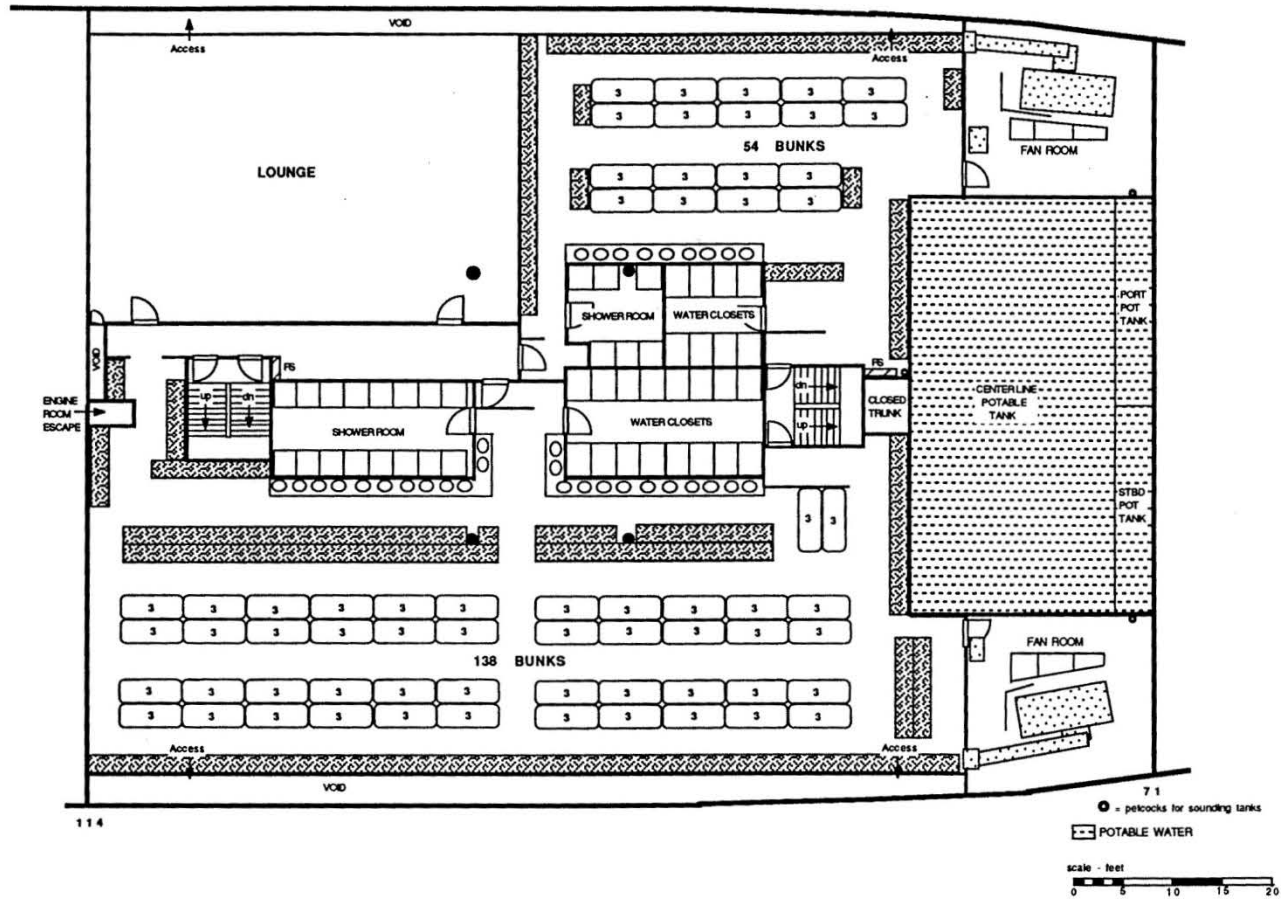

3 HOLD / D DECK

TRAINING CLASSROOMS

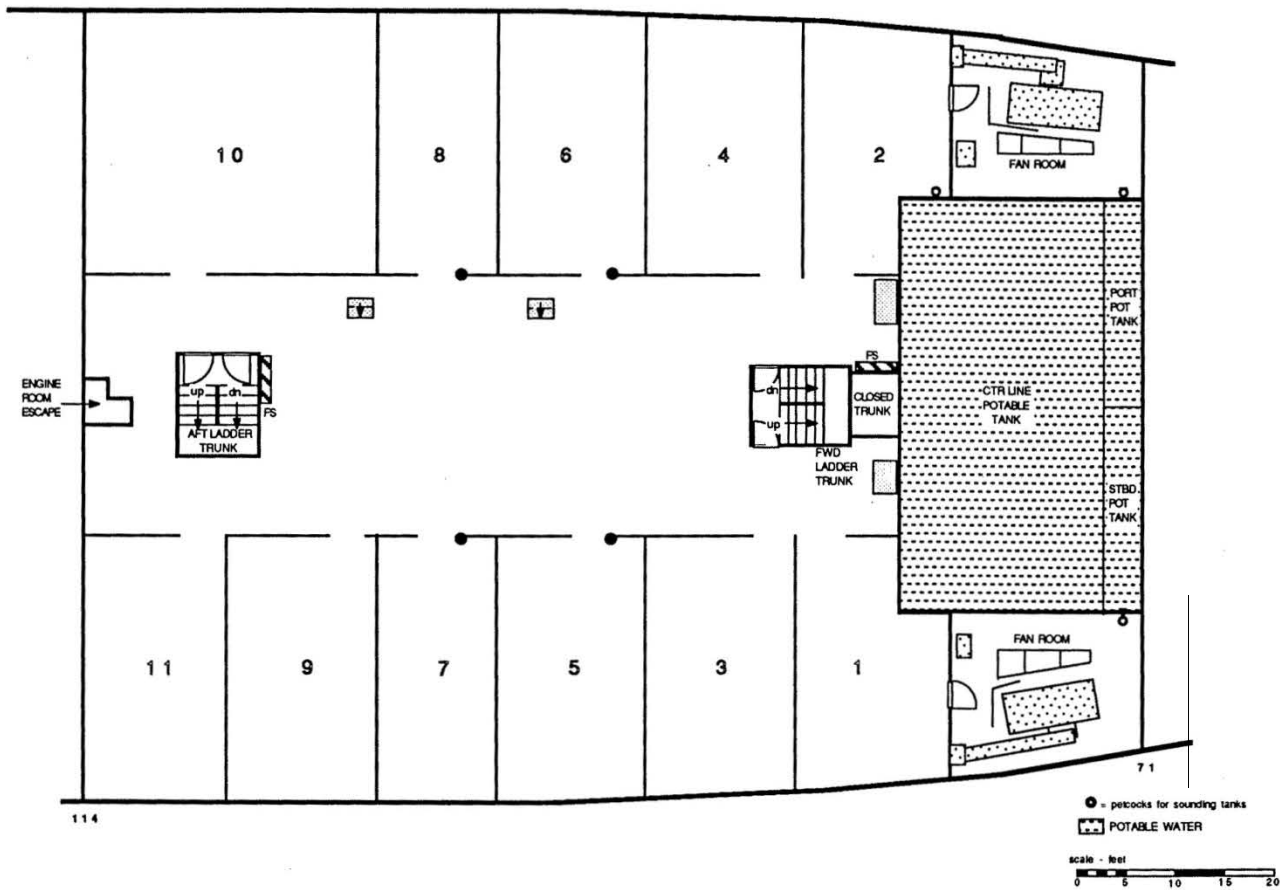

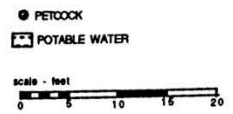
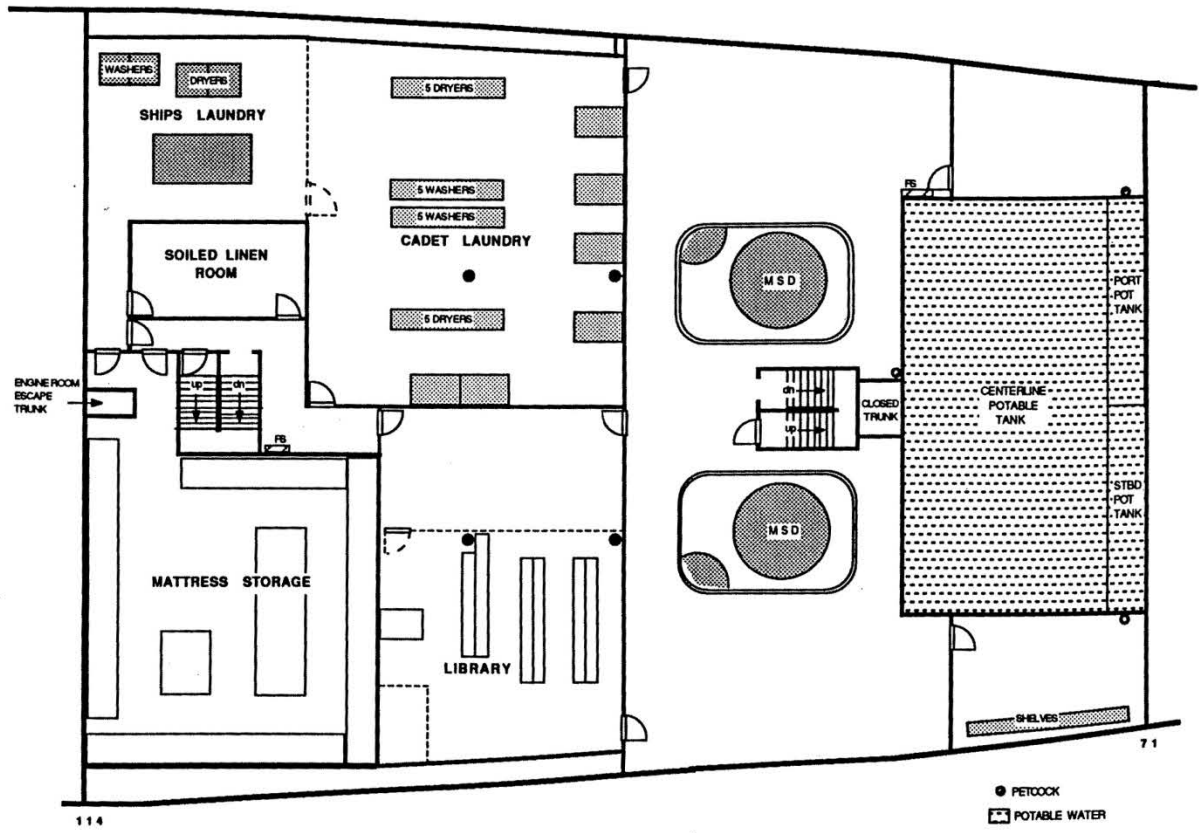

3 HOLD / E DECK

LAUNDRY AND LIBRARY

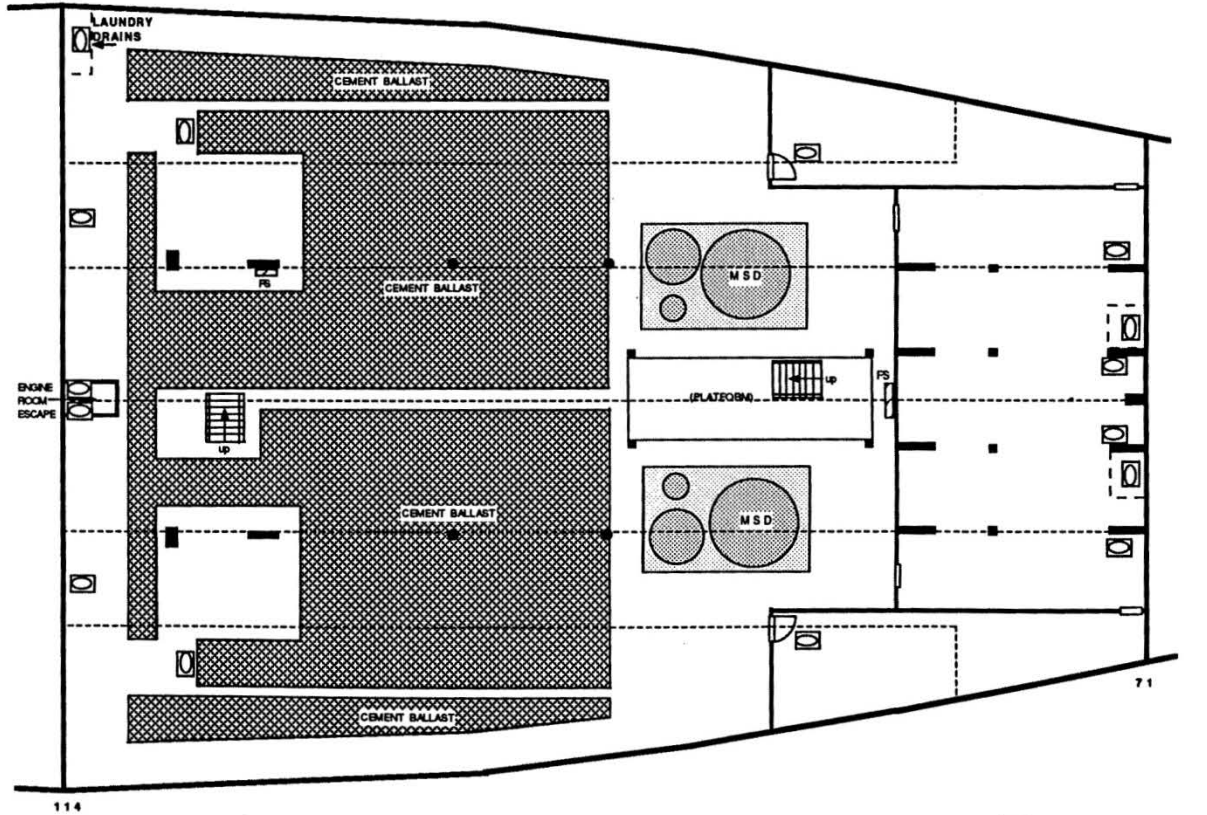

3 HOLD / TT DECK
BALLAST AND M.S.D.



 SOLID BALLAST
 scale - feet
 0 5 10 15 20

3 HOLD / INNERBOTTOM TANKS

BALLAST AND M.S.D.

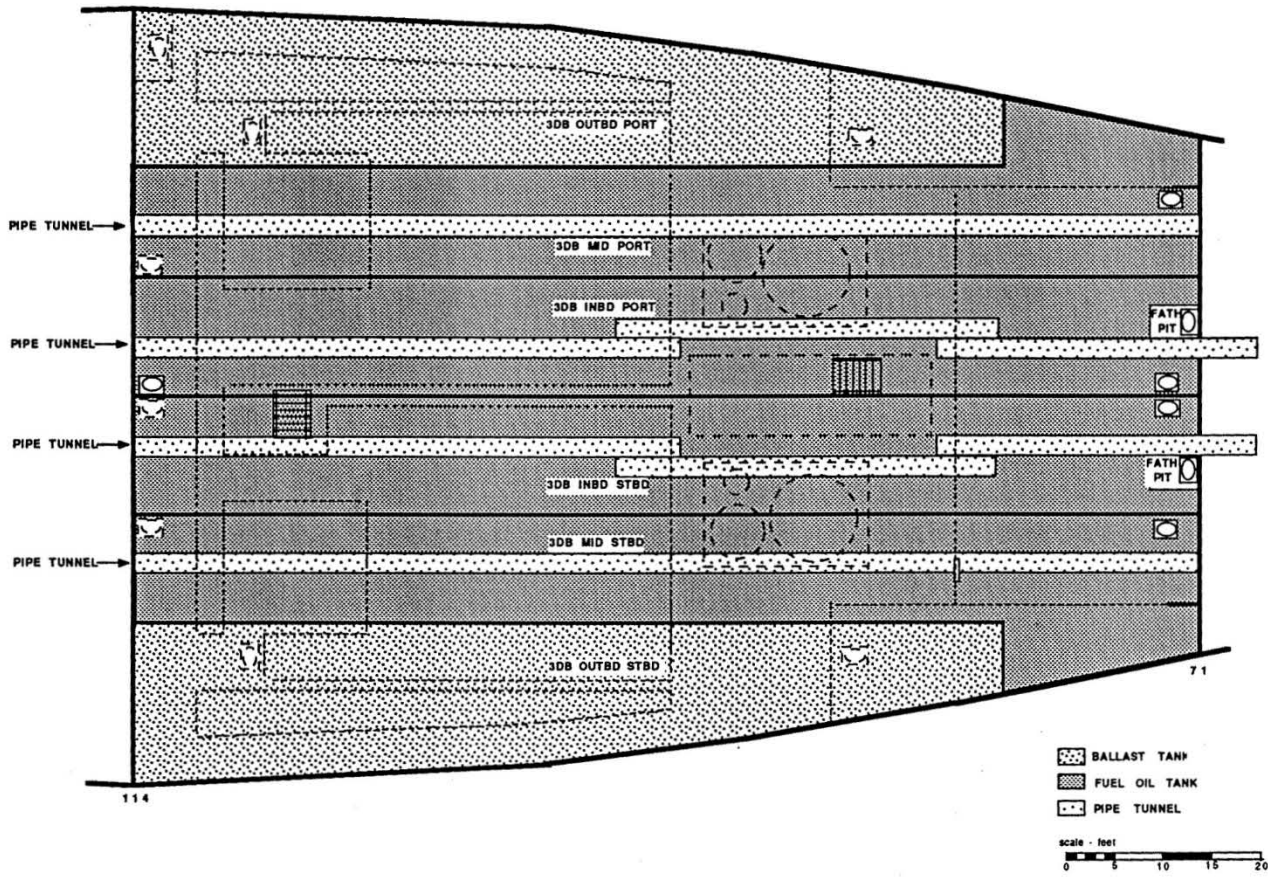

BOOKLET OF PLANS

4 HOLD PRINTS

B DECK

C DECK

D DECK

E DECK

DEEP TANKS

INNERBOTTOM TANKS

4 HOLD / B DECK
TRAINING AREA

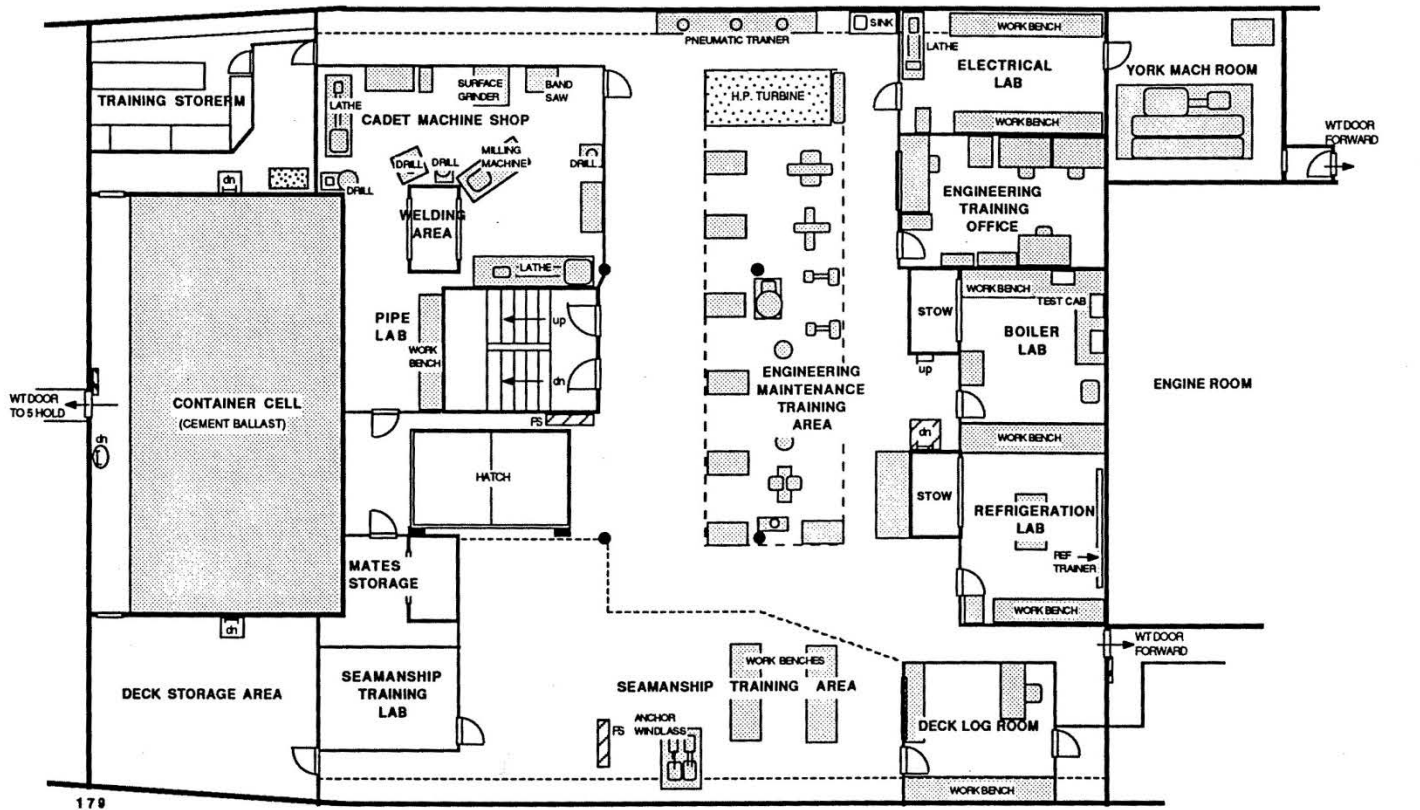

138
12 INCHES OF CEMENT ON THE DECK FOR BALLAST

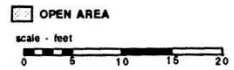

4 HOLD / C DECK
PARTS STORAGE

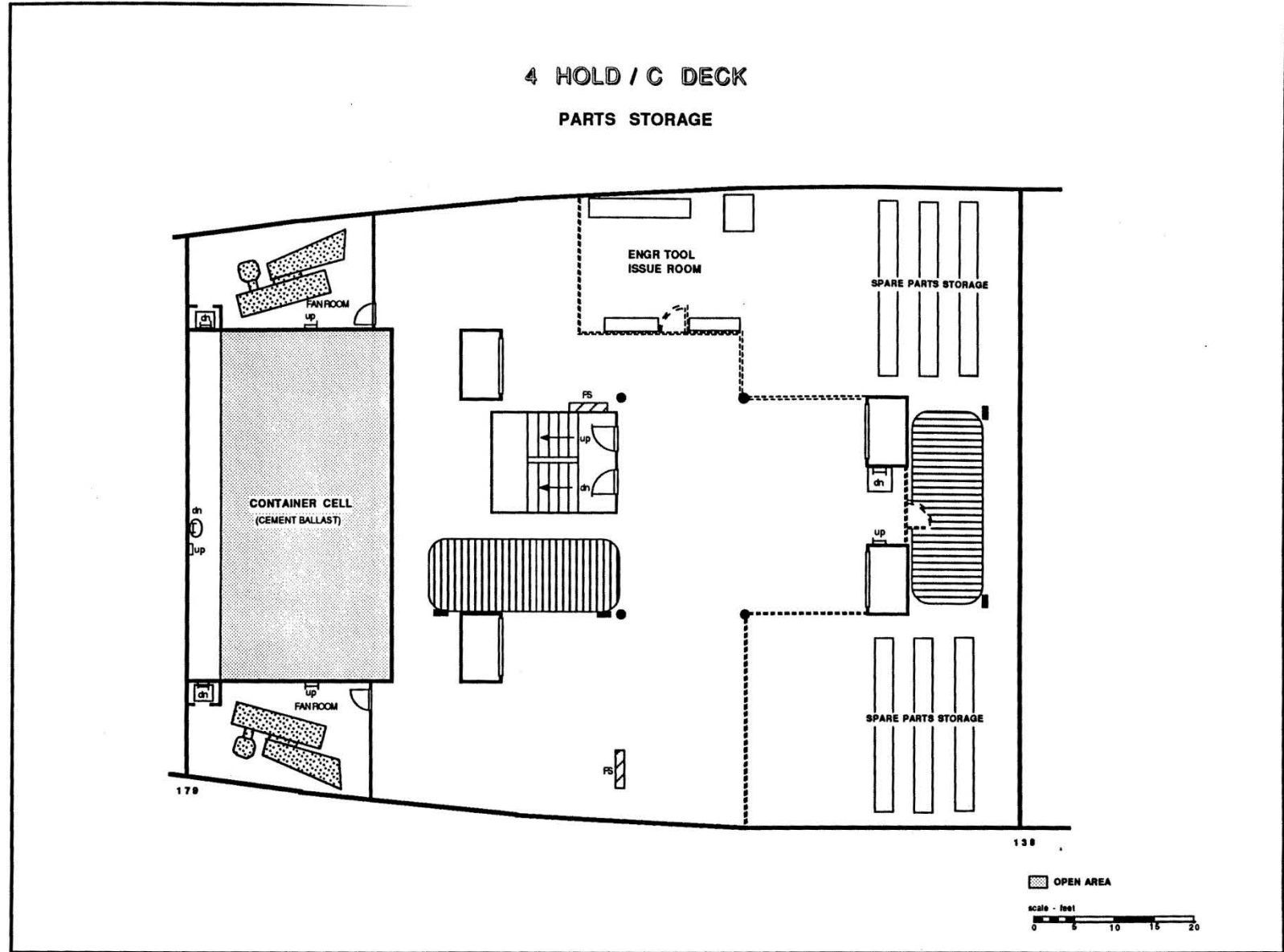

4 HOLD / D DECK

GYM

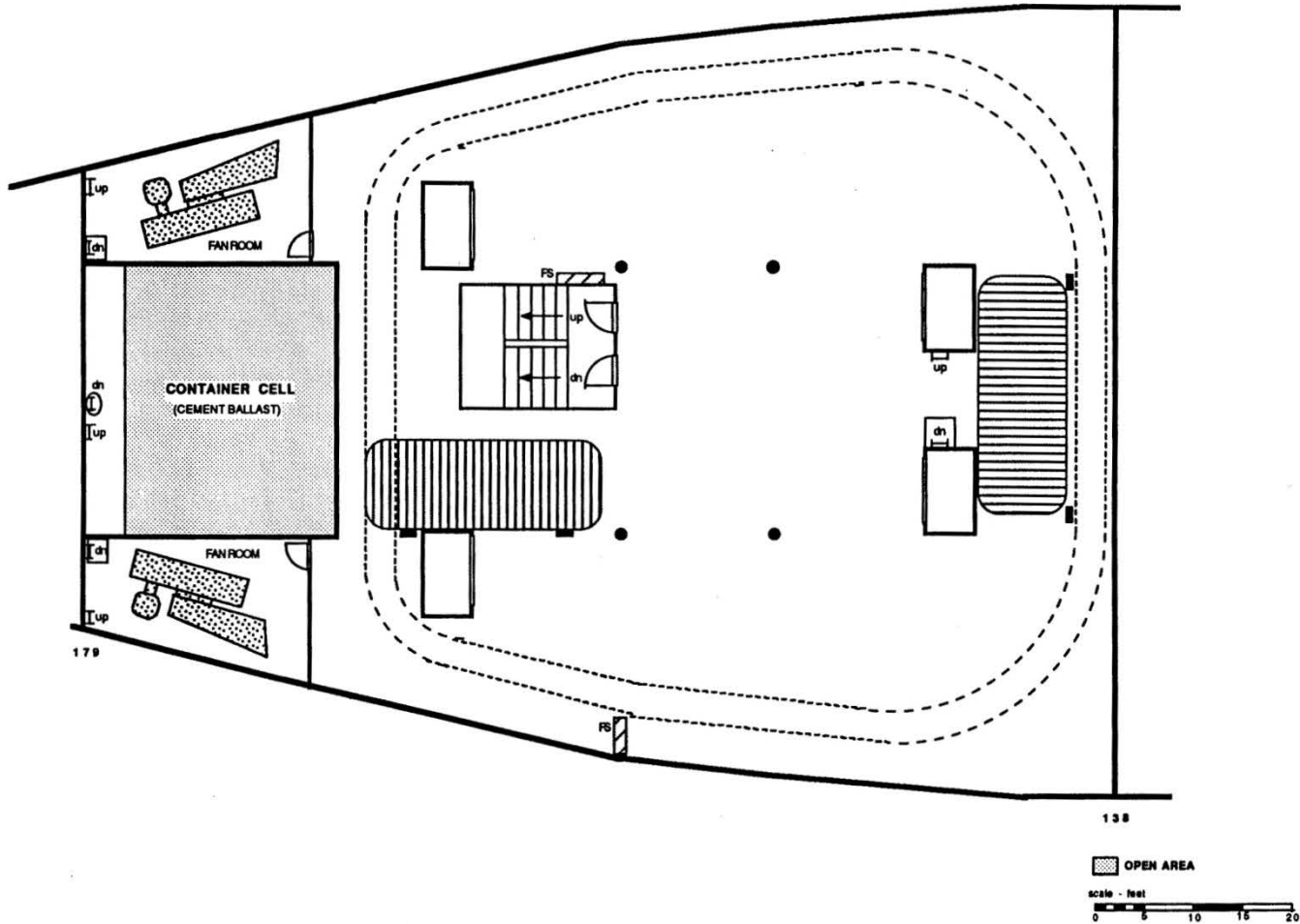

4 HOLD / E DECK

UNUSED

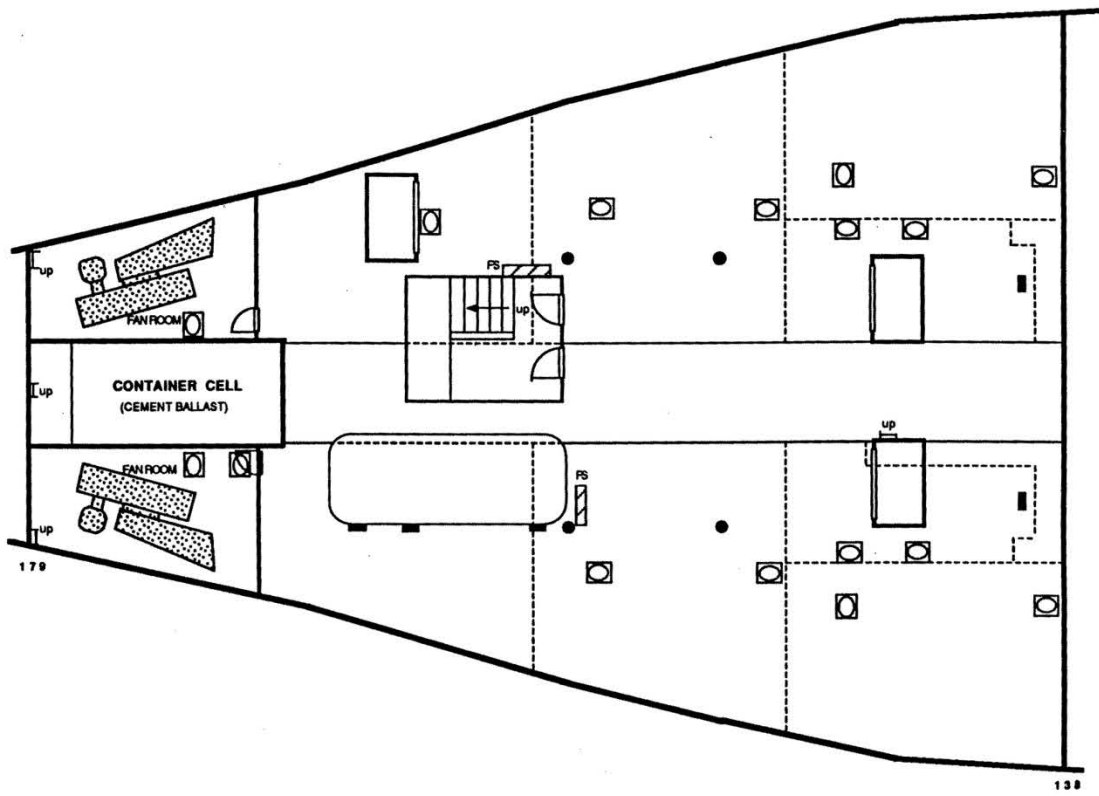

4 HOLD/ TANK TOP DECK

DEEP TANKS

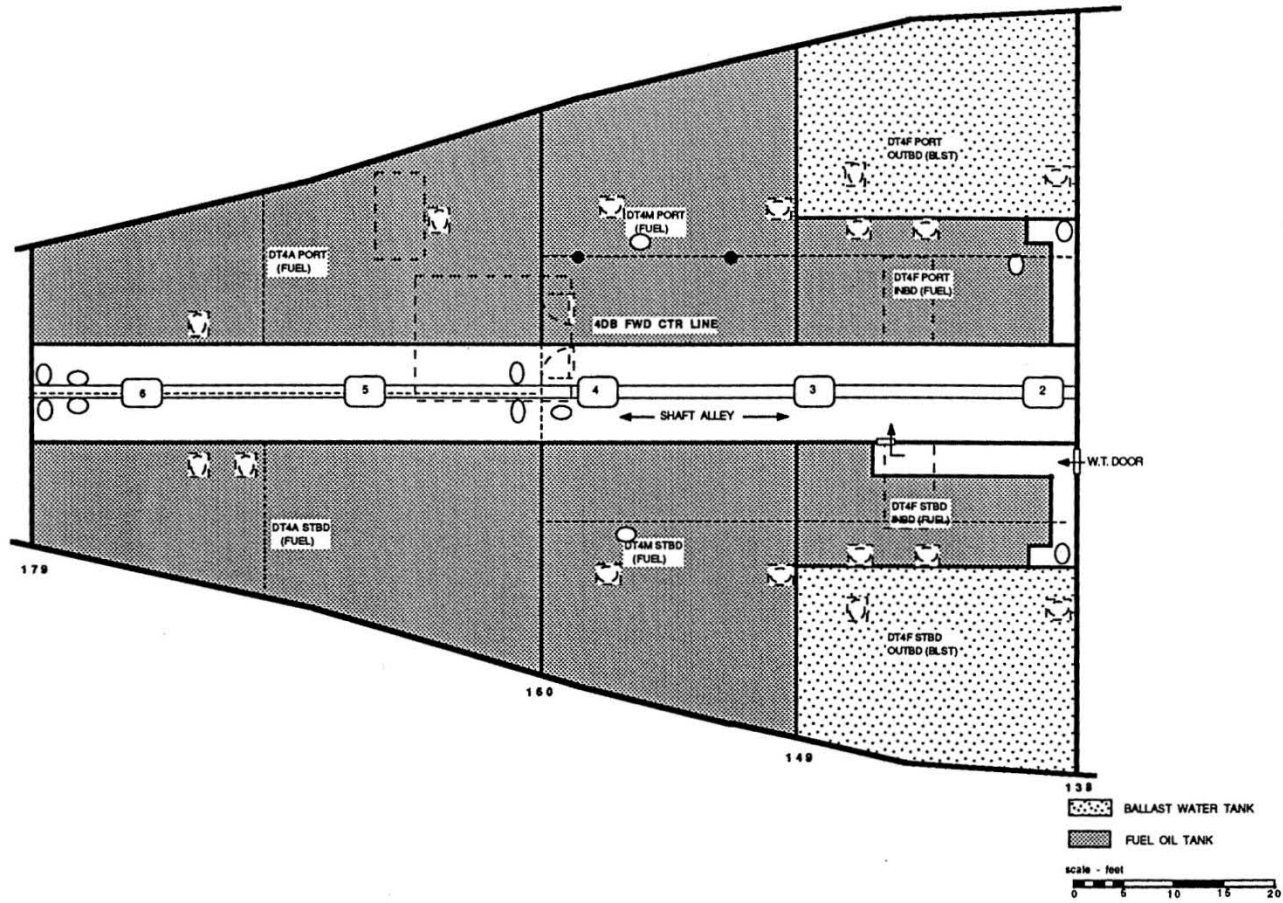

4 HOLD/ INNERBOTTOM
INNERBOTTOM TANKS

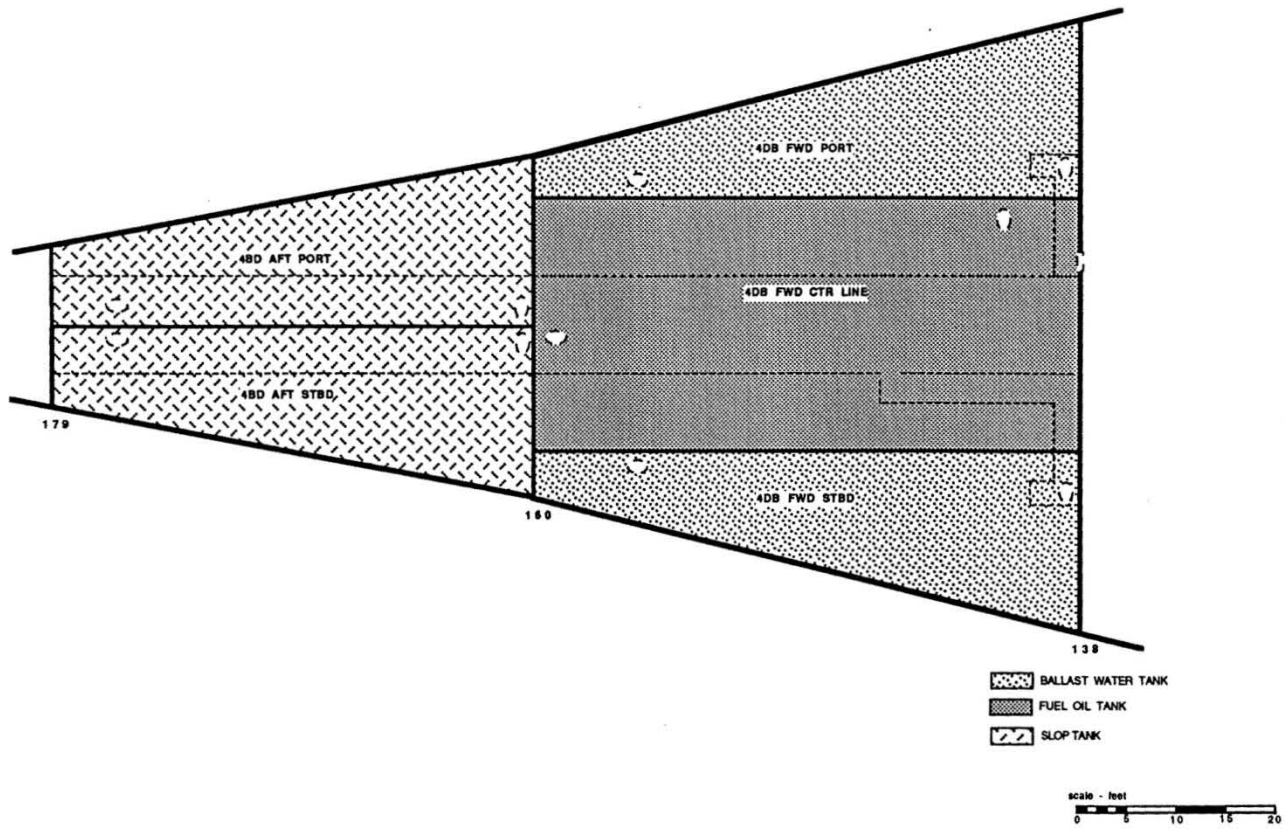

BOOKLET OF PLANS

FANTAIL & 5 HOLD PRINTS

FANTAIL & MAIN DECK

B DECK

C DECK

D DECK

E DECK

TANK TOP DECK

INNERBOTTOM TANKS

5 HOLD / FANTAIL & MAIN DECK

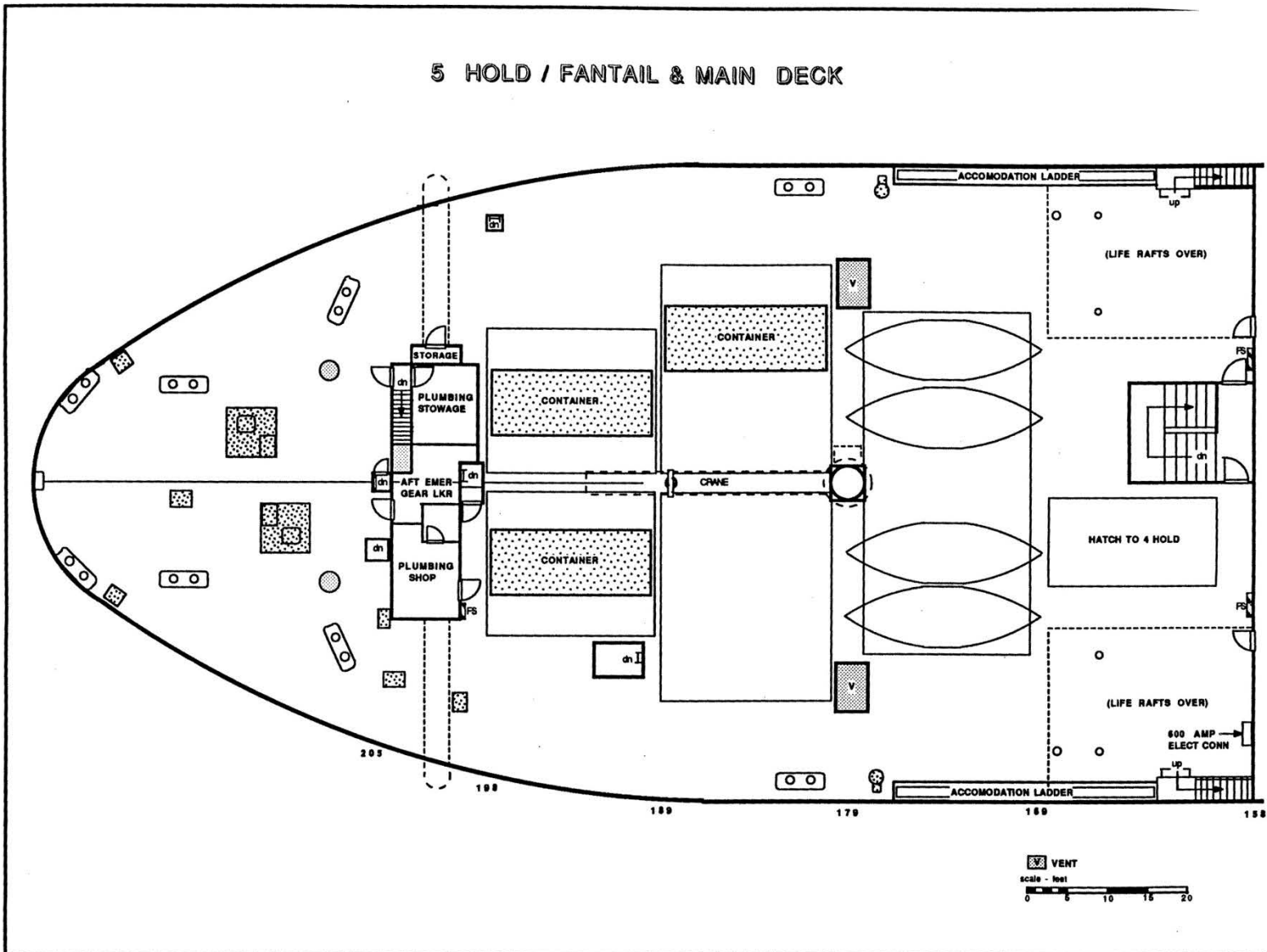

5 HOLD / B DECK

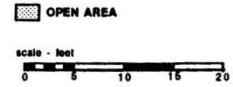
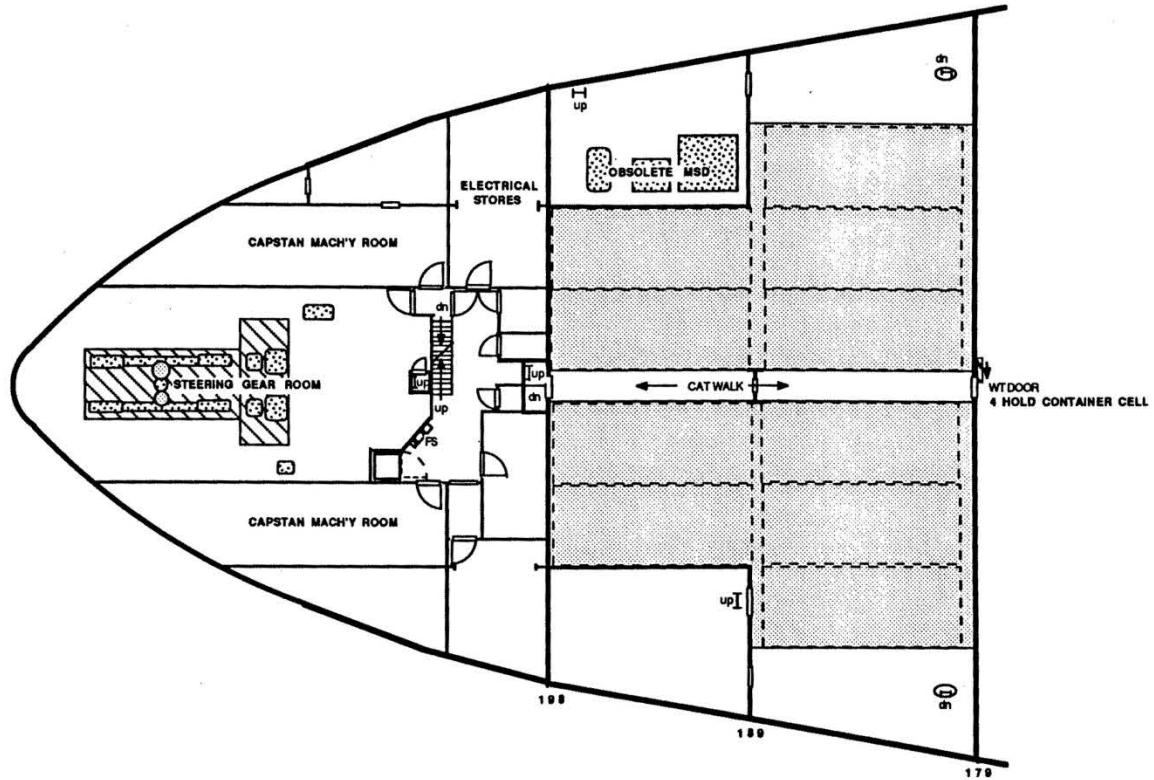

5 HOLD / C DECK

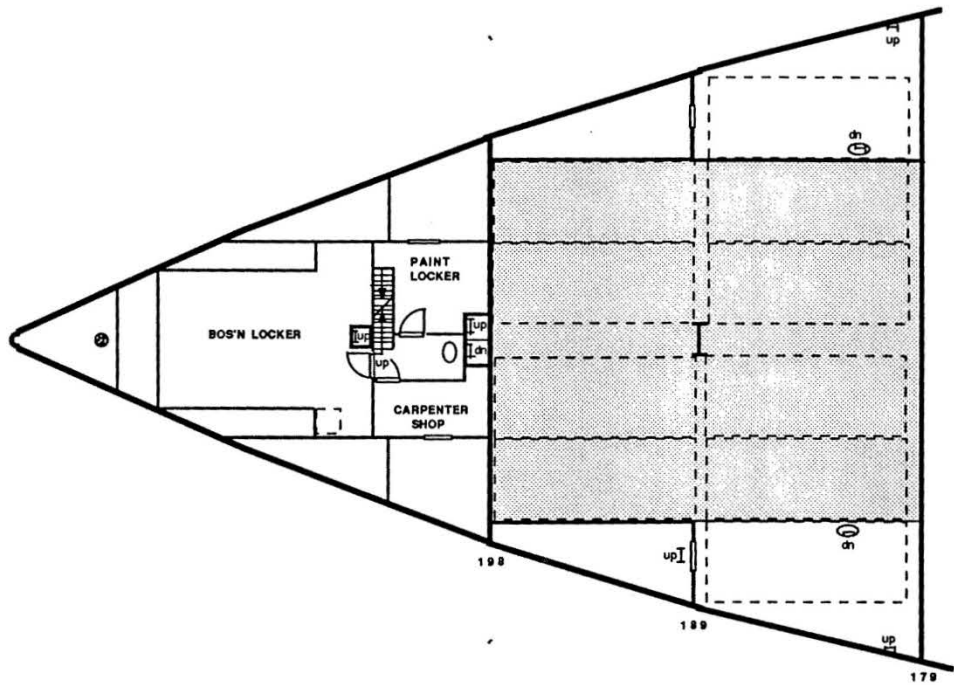

OPEN AREA

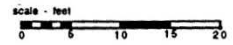

5 HOLD / D DECK

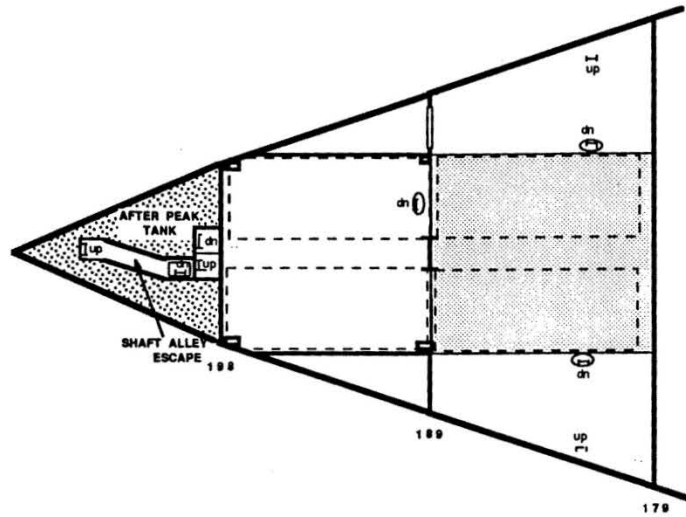

 BALLAST TANK
 OPEN AREA

scale - feet
0 5 10 15 20

5 HOLD / E DECK

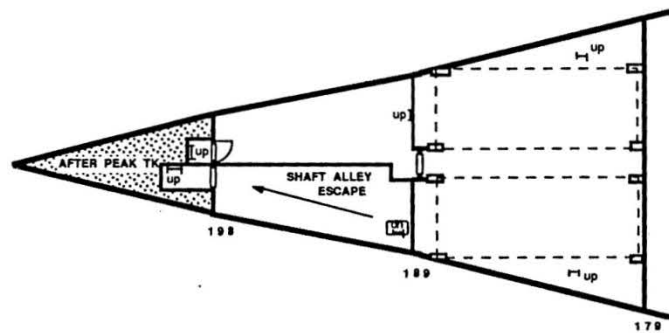

 BALLAST TANK

scale - feet
0 5 10 15 20

5 HOLD / TT DECK

SHAFT ALLEY

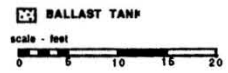
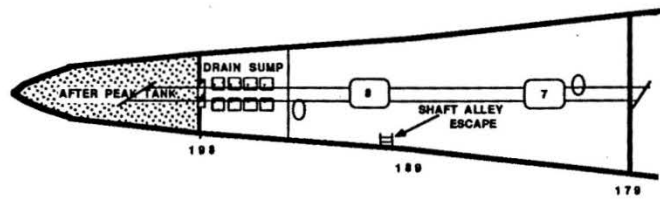

5 HOLD / INNERBOTTOM TANKS

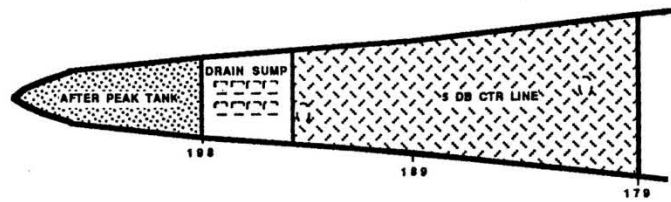

LIQUID BALLAST
SLOP TANK

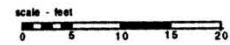

STATISTICS

GENERAL

OFFICIAL NO.: DN293943
 MARAD CLASS: "M" CLASS
 CALL SIGN: WHBH
 LENGTH OVERALL: 546' 7 5/8"
 BETWEEN PERPENDICULARS 508' 6"
 BEAM: 79'
 DRAFT: 26'
 LIGHTSHIP WEIGHT 12,584 L.T.
 NORMAL HORSEPOWER: 18,000 @ 115RPM

BERTHING

HOUSE GENERAL- 170
 HOUSE CADETS- 83
 3 HOLD B DECK CADETS- 304
 3 HOLD C DECK CADETS- 192
 MAXIMUM PASS/CADETS- 693

LIFEBOAT CAPACITY

BOAT 1 (DIESEL) 145
 BOAT 2 (DIESEL) 145
 BOAT 3 41
 BOAT 4 41
 BOAT 5 (DIESEL) 74
 BOAT 6 78
 EACH OF 8 RAFTS 25

TANK CAPACITIES

FUEL OIL: (98%)

3DB M PORT 776 bbls
 3DB M STBD 772 bbls
 3DB IB PORT 957 bbls
 3DB IB STBD 957 bbls
 DBMS IB PORT 379 bbls
 DBMS IB STBD 391 bbls
 DBMS AFT PORT 137 bbls
 DBMS AFT STBD 137 bbls
 4DB C/L 1053 bbls
 4DT F IB PORT 445 bbls
 4DT F IB STBD 376 bbls
 4DT MID PORT 809 bbls
 4DT MID STBD 809 bbls
 4DT AFT PORT 742 bbls
 4DT AFT STBD 732 bbls
 IB PORT SETT 405 bbls
 IB STBD SETT 403 bbls
 OB PORT SETT 396 bbls
 OB STBD SETT 396 bbls
 TOTAL 11,072 bbls

DIESEL OIL:

DBMS 2,687 gal
 EMER DIESEL 600 gal

LUBE OIL:

GRAVITY TANK 1,995 gal
 STORAGE TANK 3,615 gal
 SETTLER TANK 3,615 gal
 SUMP 1,590 gal

SLOP TANK:

4DB A PORT 14,345 gal
 4DB A STBD 14,345 gal
 5DB C/L 11,101 gal

POTABLE WATER:

PORT 15,311 gal
 STBD 15,311 gal
 CENTER LINE 161,657 gal
 TOTAL 192,279 gal
 697 tons

RESERVE FEED WATER:

DB PORT 8,334 gal
 DB STBD 8,352 gal
 TOTAL 16,686 gal
 62 tons

BALLAST

LIQUID BALLAST: (100%)

	WEIGHT	
FORE PEAK	29,865 gal	114 tons
1DT F C/L	64,175 gal	245 tons
1DT/1DB A PORT	44,941 gal	172 tons
1DT/1DB A STBD	45,166 gal	173 tons
2DB PORT	9,422 gal	36 tons
2DB C/L	23,966 gal	93 tons
2DB STBD	9,422 gal	36 tons
3DB OUT PORT	20,866 gal	80 tons
3DB OUT STBD	20,866 gal	80 tons
DBMS OUT PORT	13,332 gal	51 tons
DBMS OUT STBD	13,090 gal	50 tons
4DB F PORT	12,314 gal	47 tons
4DB F STBD	12,314 gal	47 tons
4DT F OUT PORT	23,568 gal	90 tons
4DT F OUT STBD	23,568 gal	90 tons
AFT PEAK	41,652 gal	159 tons
TOTAL	408,527 gal	1714 tons

SOLID BALLAST

	FIXED/REMOVABLE	WEIGHT
1 HOLD, D DECK	132	132 tons
2 HOLD (62)	1239	1239 tons
3 HOLD, TT DECK	421	421 tons
HOUSE, MAIN DECK	110	110 tons
4 HOLD, B DECK	334	334 tons
4 HOLD, CONT CELL (8)	160	160 tons
5 HOLD (18)	361	361 tons
TOTAL	997	1760

TOTAL LIQUID AND SOLID BALLAST 4471 tons

HISTORIC AMERICAN ENGINEERING RECORD

INDEX TO PHOTOGRAPHS

HAER VA-135

PATRIOT STATE
(*Santa Mercedes*)
James River Reserve Fleet
Newport News vicinity
Virginia

Photographs were taken when the ship was moored at the James River Reserve Fleet of the U.S. Maritime Administration prior to it being dismantled.

INDEX TO BLACK AND WHITE PHOTOGRAPHS

Jet Lowe, photographer, 2008

- | | |
|-----------|--|
| VA-135-1 | Starboard elevation (all shots from the water were taken with a 5x7 Master Technika, hand held). |
| VA-135-2 | Starboard bow quarter. |
| VA-135-3 | Oblique perspective of starboard bow quarter. |
| VA-135-4 | Bow elevation. |
| VA-135-5 | Port bow quarter in perspective. |
| VA-135-6 | Port side stern quarter. |
| VA-135-7 | Port elevation and profile. |
| VA-135-8 | Stern elevation. |
| VA-135-9 | View looking forward from bridge. |
| VA-135-10 | Bow point, looking forward. |
| VA-135-11 | Boat deck machinery in bow area. |
| VA-135-12 | Detail of 20-ton boom pulley. |
| VA-135-13 | Deck looking aft to bridge. |
| VA-135-14 | View aft of bridge and storage hatch. |

PATRIOT STATE
HAER VA-135
INDEX TO PHOTOGRAPHS

- VA-135-15 Binnacle on upper bridge deck.
- VA-135-16 Ship's stack, looking aft.
- VA-135-17 View aft from bridge deck.
- VA-135-18 Aft side of promenade lounge. "A" deck with swimming pool in middle ground.
- VA-135-19 Port side of promenade deck, looking forward with lifeboats in foreground.
- VA-135-20 Crane, aft section of Hold 4.
- VA-135-21 Caps to storage hold aft, looking to port.
- VA-135-22 Stern or aft bridge.
- VA-135-23 Oversized machinery wrenches (capstan, propellor, shaft).
- VA-135-24 Bridge, looking forward.
- VA-135-25 Massachusetts Maritime Academy logo, aft of the amidships house.
- VA-135-26 Forward storage hold with a collection of toilets.
- VA-135-27 Banana storage hold in elevator shaft.
- VA-135-28 Cadet berthing, "B" deck.
- VA-135-29 Stateroom, passenger deck.
- VA-135-30 Stateroom, "A" deck.
- VA-135-31 Main bridge, looking to port.
- VA-135-32 Stairwell, promenade deck.
- VA-135-33 Wall map outside of lounge on promenade deck, which dates to ship's use as passenger freighter.
- VA-135-34 Main galley, second deck.
- VA-135-35 Port mess hall off galley on second deck.
- VA-135-36 Lounge bar, right side of panorama.
- VA-135-37 Lounge, left side of panorama.
- VA-135-38 Starboard generators and electrical distribution panel.

PATRIOT STATE
HAER VA-135
INDEX TO PHOTOGRAPHS

- VA-135-39 Engine room, port side machinery. Right side of panorama consisting of HAER Nos. VA-135-39, 40, and 41. High pressure turbine and reduction gears in center.
- VA-135-40 Center image of port side machinery in engine room.
- VA-135-41 Control panels, left side of panorama. The photographs can be stitched digitally or viewed separately.
- VA-135-42 Engine room on upper level looking aft at the engine control panel and PLS boilers.
- VA-135-43 Engine room on lower level, looking starboard at the port condenser and inlet valve.
- VA-135-44 Lower level engine room, looking forward to the reduction gear and shaft.
- VA-135-45 Ship's shaft with thrust bearing at the end, looking aft.
- VA-135-46 Reefer storage for food, looking starboard.
- VA-135-47 Hold 4, "D" deck, converted to gym with weights and a training track by Massachusetts Maritime Academy cadets.
- VA-135-48 Hold 4, "A" deck, where training schools and labs were held. Detail of knot board.
- VA-135-49 Hold 4, "A" deck, school training labs. Rooms 2 and 3 looking at port side.
- VA-135-50 Hold 4, "A" deck, navigation training room.
- VA-135-51 Hold 4, "A" deck, refrigeration training room.
- VA-135-52 Hold 4, school training lab, looking aft.
- VA-135-53 Steering gear, looking aft. Manufactured by C.H. Wheeler Mfg. Co.
- VA-135-54 Electro-hydraulic steering gear, looking forward.

HISTORIC AMERICAN ENGINEERING RECORD
SEE INDEX TO PHOTOGRAPHS FOR CAPTION

HAER No. VA-135-001



HISTORIC AMERICAN ENGINEERING RECORD
SEE INDEX TO PHOTOGRAPHS FOR CAPTION

HAER No. VA-135-002



HISTORIC AMERICAN ENGINEERING RECORD
SEE INDEX TO PHOTOGRAPHS FOR CAPTION

HAER No. VA-135-003



HISTORIC AMERICAN ENGINEERING RECORD
SEE INDEX TO PHOTOGRAPHS FOR CAPTION

HAER No. VA-135-004



HISTORIC AMERICAN ENGINEERING RECORD
SEE INDEX TO PHOTOGRAPHS FOR CAPTION

HAER No. VA-135-005



HISTORIC AMERICAN ENGINEERING RECORD
SEE INDEX TO PHOTOGRAPHS FOR CAPTION

HAER No. VA-135-006



HISTORIC AMERICAN ENGINEERING RECORD
SEE INDEX TO PHOTOGRAPHS FOR CAPTION

HAER No. VA-135-007



HISTORIC AMERICAN ENGINEERING RECORD
SEE INDEX TO PHOTOGRAPHS FOR CAPTION

HAER No. VA-135-008



HISTORIC AMERICAN ENGINEERING RECORD
SEE INDEX TO PHOTOGRAPHS FOR CAPTION

HAER No. VA-135-009



HISTORIC AMERICAN ENGINEERING RECORD
SEE INDEX TO PHOTOGRAPHS FOR CAPTION

HAER No. VA-135-010



HISTORIC AMERICAN ENGINEERING RECORD
SEE INDEX TO PHOTOGRAPHS FOR CAPTION

HAER No. VA-135-011



HISTORIC AMERICAN ENGINEERING RECORD
SEE INDEX TO PHOTOGRAPHS FOR CAPTION

HAER No. VA-135-012

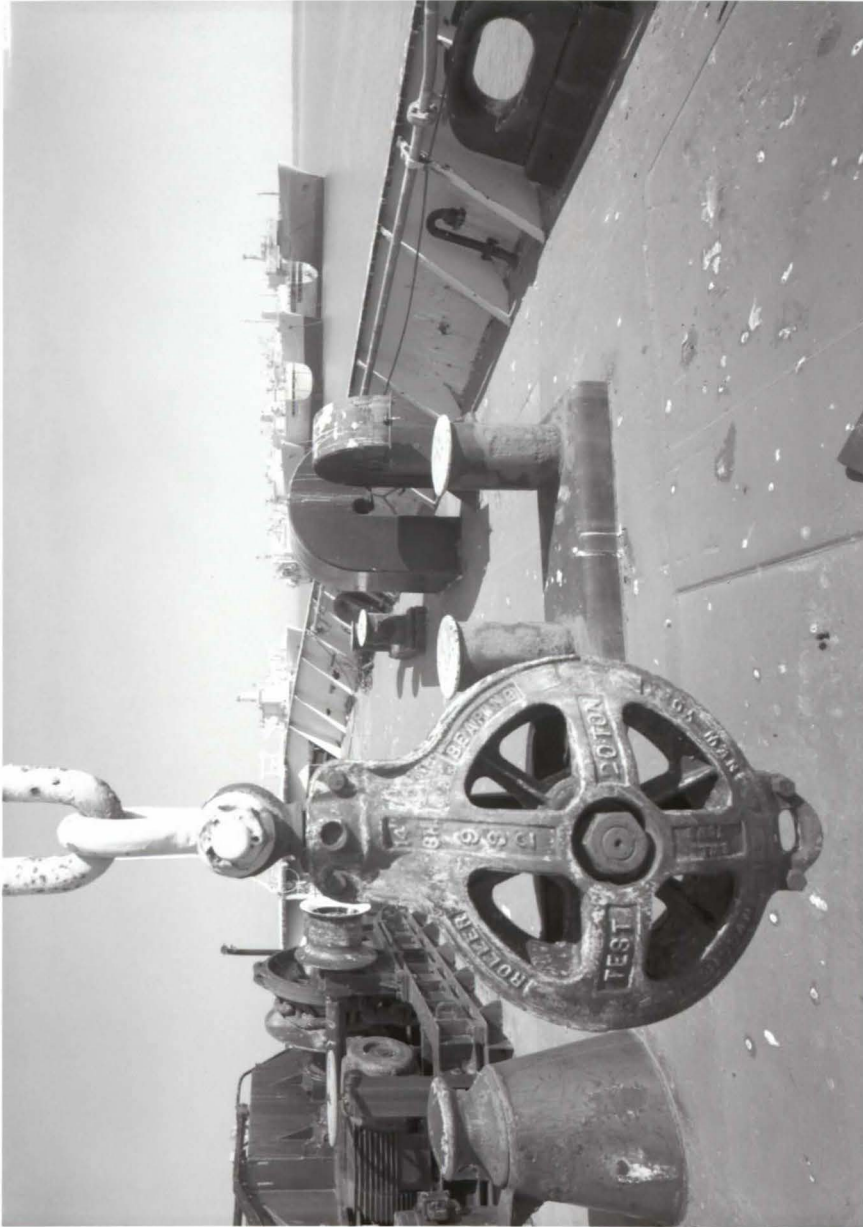

HISTORIC AMERICAN ENGINEERING RECORD
SEE INDEX TO PHOTOGRAPHS FOR CAPTION

HAER No. VA-135-013



HISTORIC AMERICAN ENGINEERING RECORD
SEE INDEX TO PHOTOGRAPHS FOR CAPTION

HAER No. VA-135-014

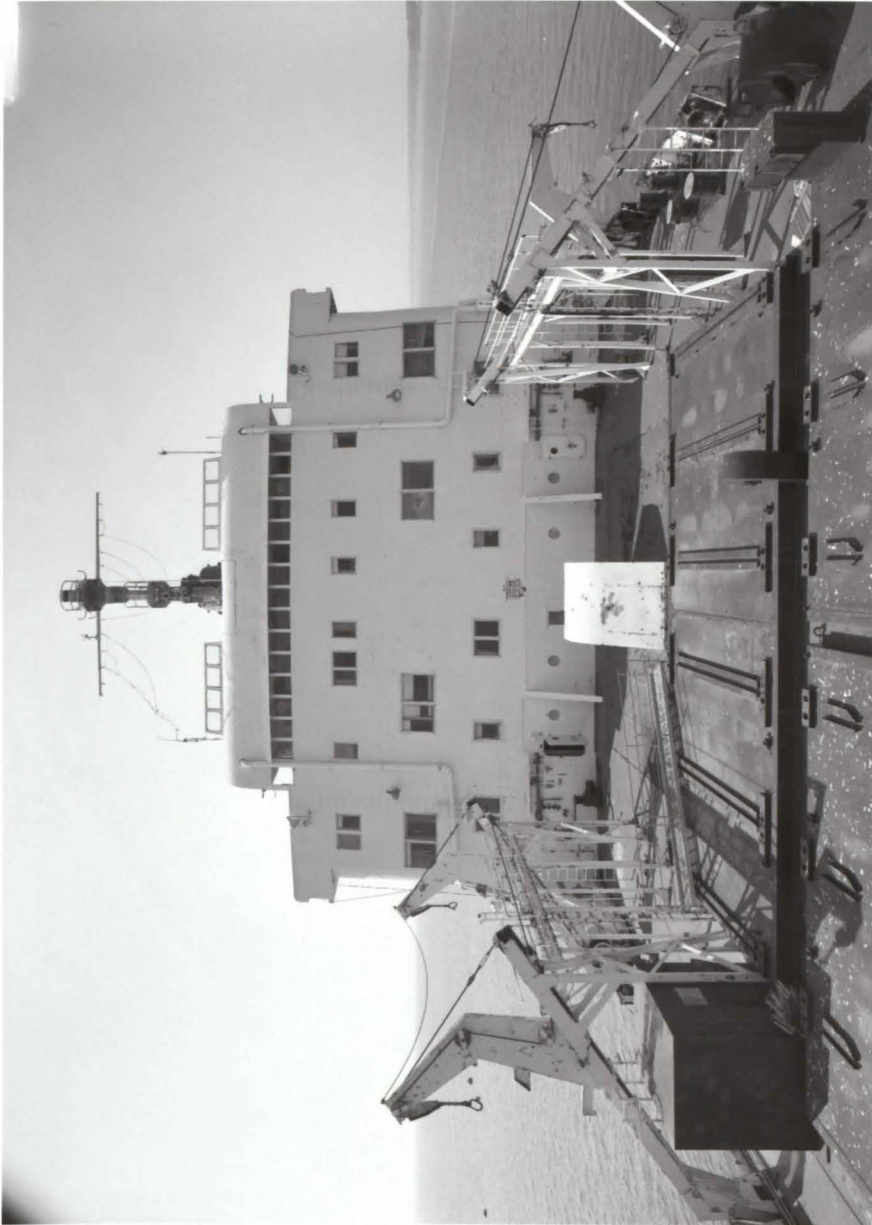

HISTORIC AMERICAN ENGINEERING RECORD
SEE INDEX TO PHOTOGRAPHS FOR CAPTION

HAER No. VA-135-015



HISTORIC AMERICAN ENGINEERING RECORD
SEE INDEX TO PHOTOGRAPHS FOR CAPTION

HAER No. VA-135-016



HISTORIC AMERICAN ENGINEERING RECORD
SEE INDEX TO PHOTOGRAPHS FOR CAPTION

HAER No. VA-135-017



HISTORIC AMERICAN ENGINEERING RECORD
SEE INDEX TO PHOTOGRAPHS FOR CAPTION

HAER No. VA-135-018



HISTORIC AMERICAN ENGINEERING RECORD
SEE INDEX TO PHOTOGRAPHS FOR CAPTION

HAER No. VA-135-019



HISTORIC AMERICAN ENGINEERING RECORD
SEE INDEX TO PHOTOGRAPHS FOR CAPTION

HAER No. VA-135-020



HISTORIC AMERICAN ENGINEERING RECORD
SEE INDEX TO PHOTOGRAPHS FOR CAPTION

HAER No. VA-135-021



HISTORIC AMERICAN ENGINEERING RECORD
SEE INDEX TO PHOTOGRAPHS FOR CAPTION

HAER No. VA-135-022



HISTORIC AMERICAN ENGINEERING RECORD
SEE INDEX TO PHOTOGRAPHS FOR CAPTION

HAER No. VA-135-023



HISTORIC AMERICAN ENGINEERING RECORD
SEE INDEX TO PHOTOGRAPHS FOR CAPTION

HAER No. VA-135-024



HISTORIC AMERICAN ENGINEERING RECORD
SEE INDEX TO PHOTOGRAPHS FOR CAPTION

HAER No. VA-135-025



HISTORIC AMERICAN ENGINEERING RECORD
SEE INDEX TO PHOTOGRAPHS FOR CAPTION

HAER No. VA-135-026



HISTORIC AMERICAN ENGINEERING RECORD
SEE INDEX TO PHOTOGRAPHS FOR CAPTION

HAER No. VA-135-027



HISTORIC AMERICAN ENGINEERING RECORD
SEE INDEX TO PHOTOGRAPHS FOR CAPTION

HAER No. VA-135-028



HISTORIC AMERICAN ENGINEERING RECORD
SEE INDEX TO PHOTOGRAPHS FOR CAPTION

HAER No. VA-135-029



HISTORIC AMERICAN ENGINEERING RECORD
SEE INDEX TO PHOTOGRAPHS FOR CAPTION

HAER No. VA-135-030



HISTORIC AMERICAN ENGINEERING RECORD
SEE INDEX TO PHOTOGRAPHS FOR CAPTION

HAER No. VA-135-031



HISTORIC AMERICAN ENGINEERING RECORD
SEE INDEX TO PHOTOGRAPHS FOR CAPTION

HAER No. VA-135-032



HISTORIC AMERICAN ENGINEERING RECORD
SEE INDEX TO PHOTOGRAPHS FOR CAPTION

HAER No. VA-135-033

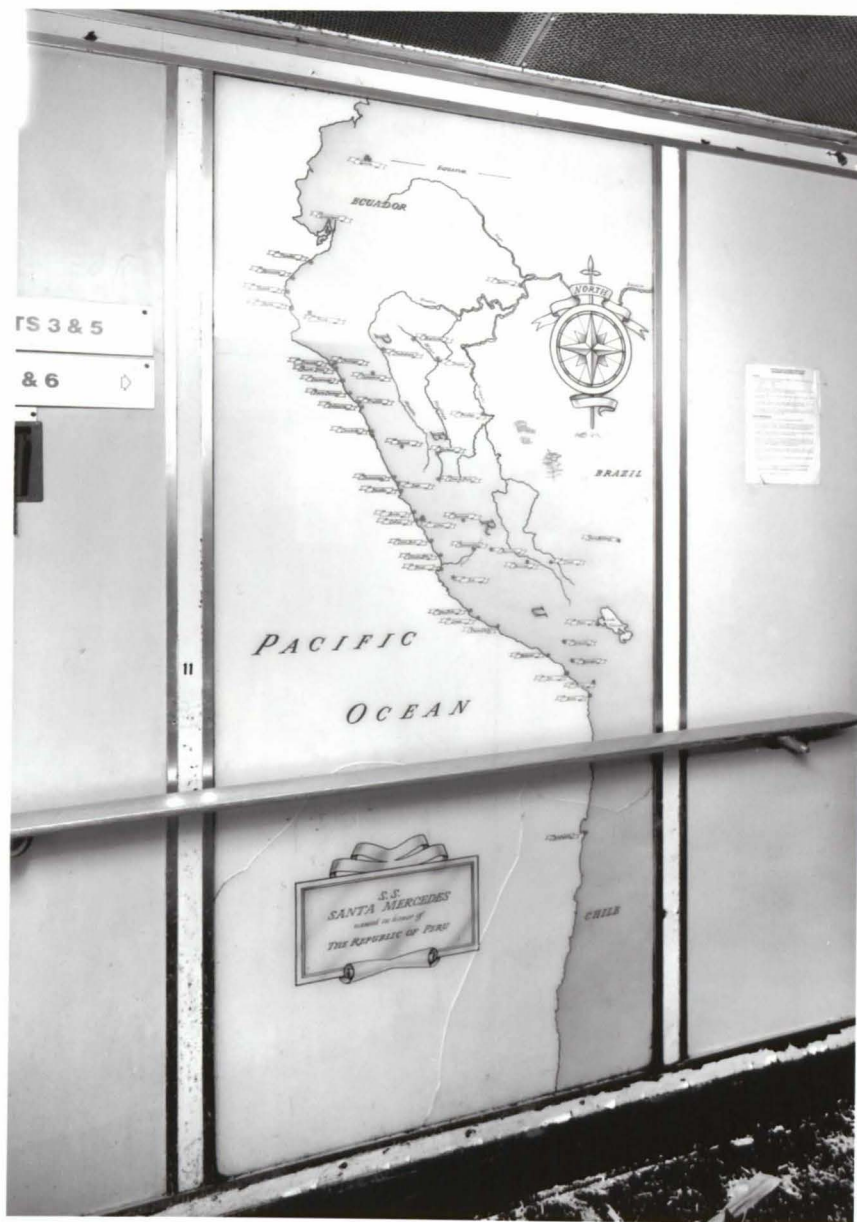

HISTORIC AMERICAN ENGINEERING RECORD
SEE INDEX TO PHOTOGRAPHS FOR CAPTION

HAER No. VA-135-034



HISTORIC AMERICAN ENGINEERING RECORD
SEE INDEX TO PHOTOGRAPHS FOR CAPTION

HAER No. VA-135-035



HISTORIC AMERICAN ENGINEERING RECORD
SEE INDEX TO PHOTOGRAPHS FOR CAPTION

HAER No. VA-135-036



HISTORIC AMERICAN ENGINEERING RECORD
SEE INDEX TO PHOTOGRAPHS FOR CAPTION

HAER No. VA-135-037



HISTORIC AMERICAN ENGINEERING RECORD
SEE INDEX TO PHOTOGRAPHS FOR CAPTION

HAER No. VA-135-038

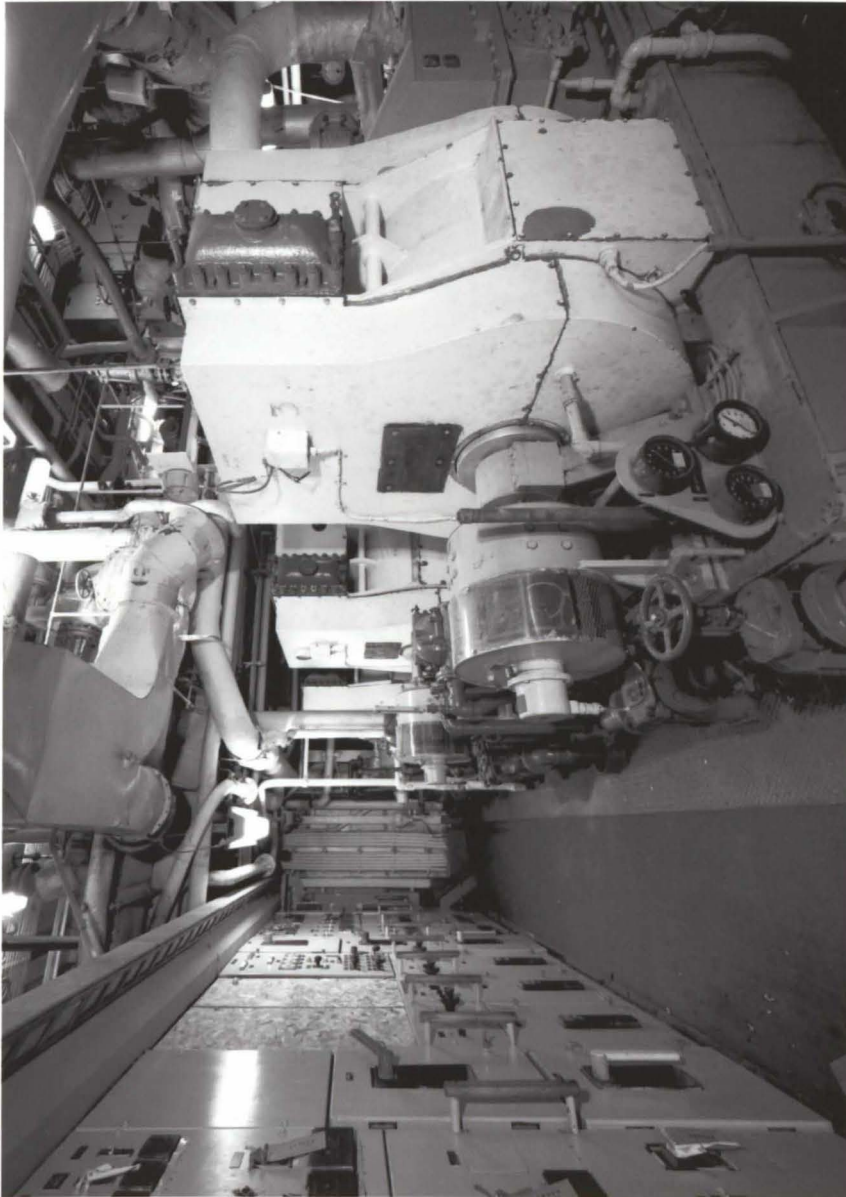

HISTORIC AMERICAN ENGINEERING RECORD
SEE INDEX TO PHOTOGRAPHS FOR CAPTION

HAER No. VA-135-039

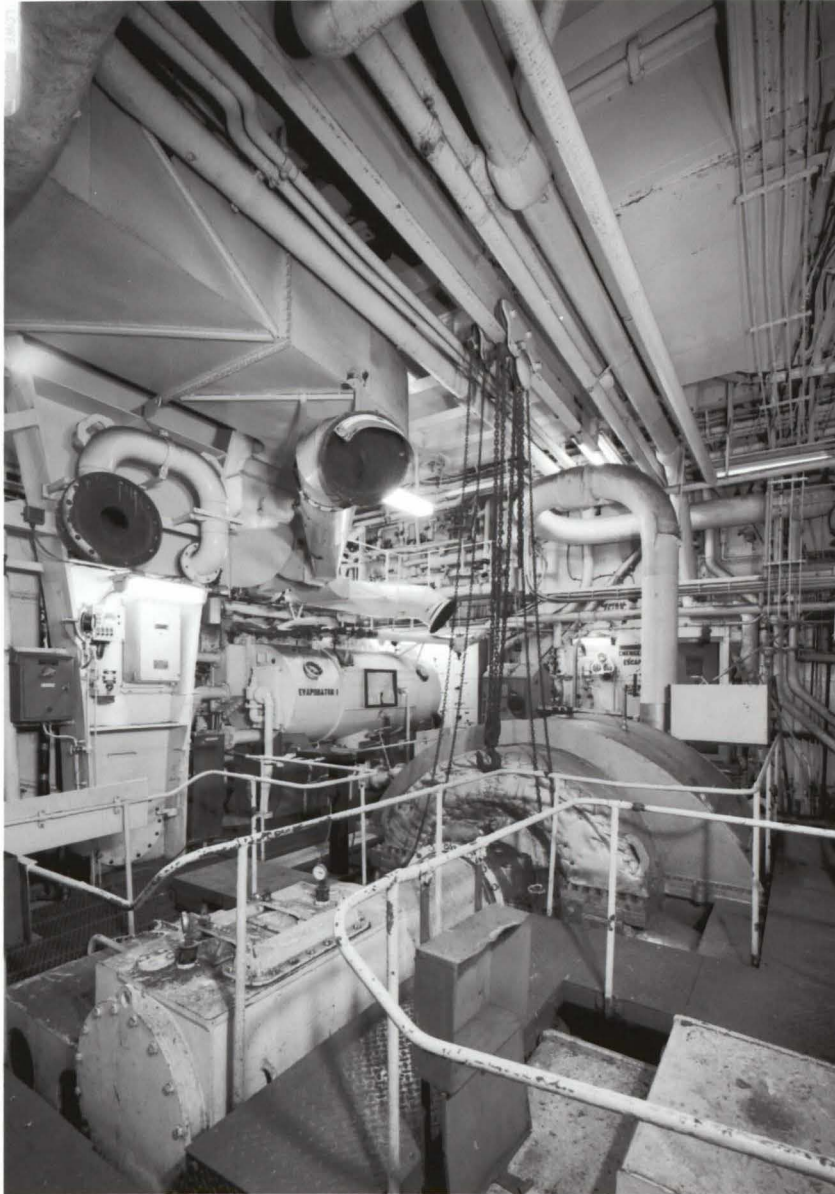

HISTORIC AMERICAN ENGINEERING RECORD
SEE INDEX TO PHOTOGRAPHS FOR CAPTION

HAER No. VA-135-040

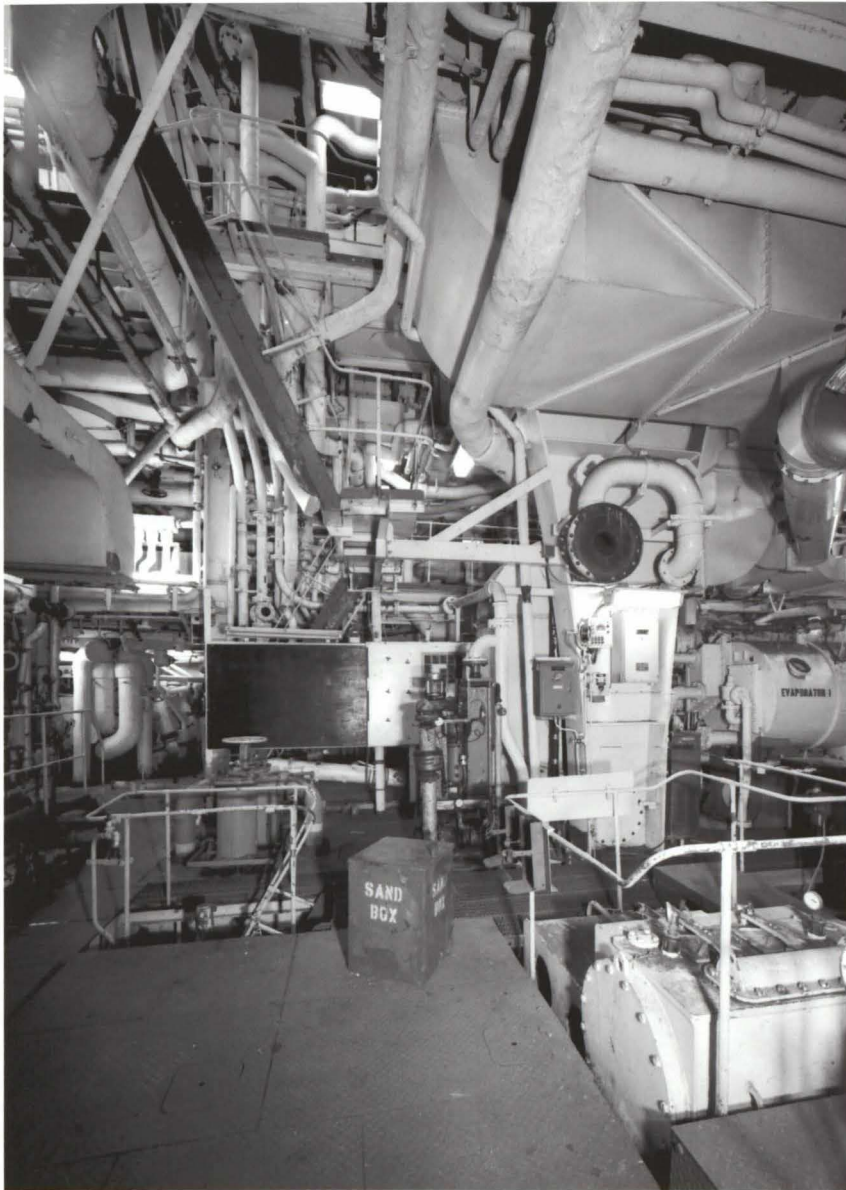

HISTORIC AMERICAN ENGINEERING RECORD
SEE INDEX TO PHOTOGRAPHS FOR CAPTION

HAER No. VA-135-041

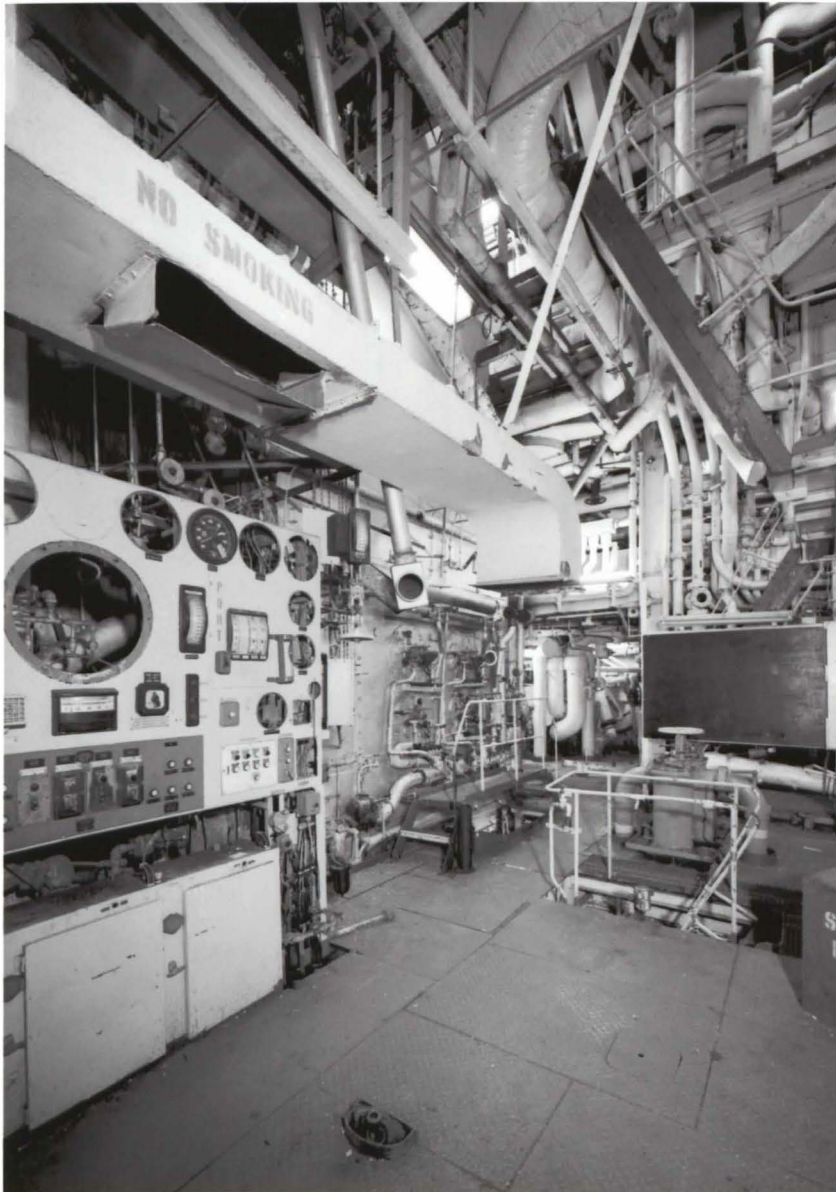

HISTORIC AMERICAN ENGINEERING RECORD
SEE INDEX TO PHOTOGRAPHS FOR CAPTION

HAER No. VA-135-042

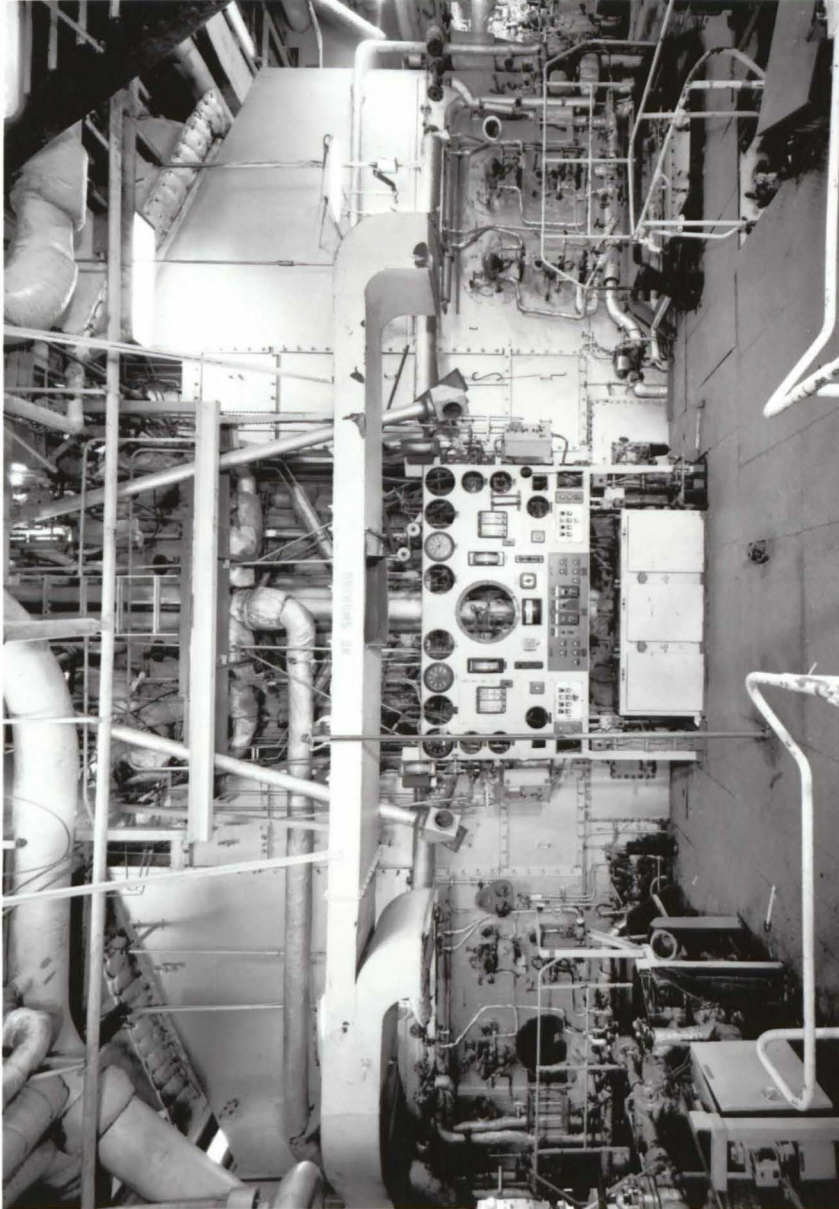

HISTORIC AMERICAN ENGINEERING RECORD
SEE INDEX TO PHOTOGRAPHS FOR CAPTION

HAER No. VA-135-043

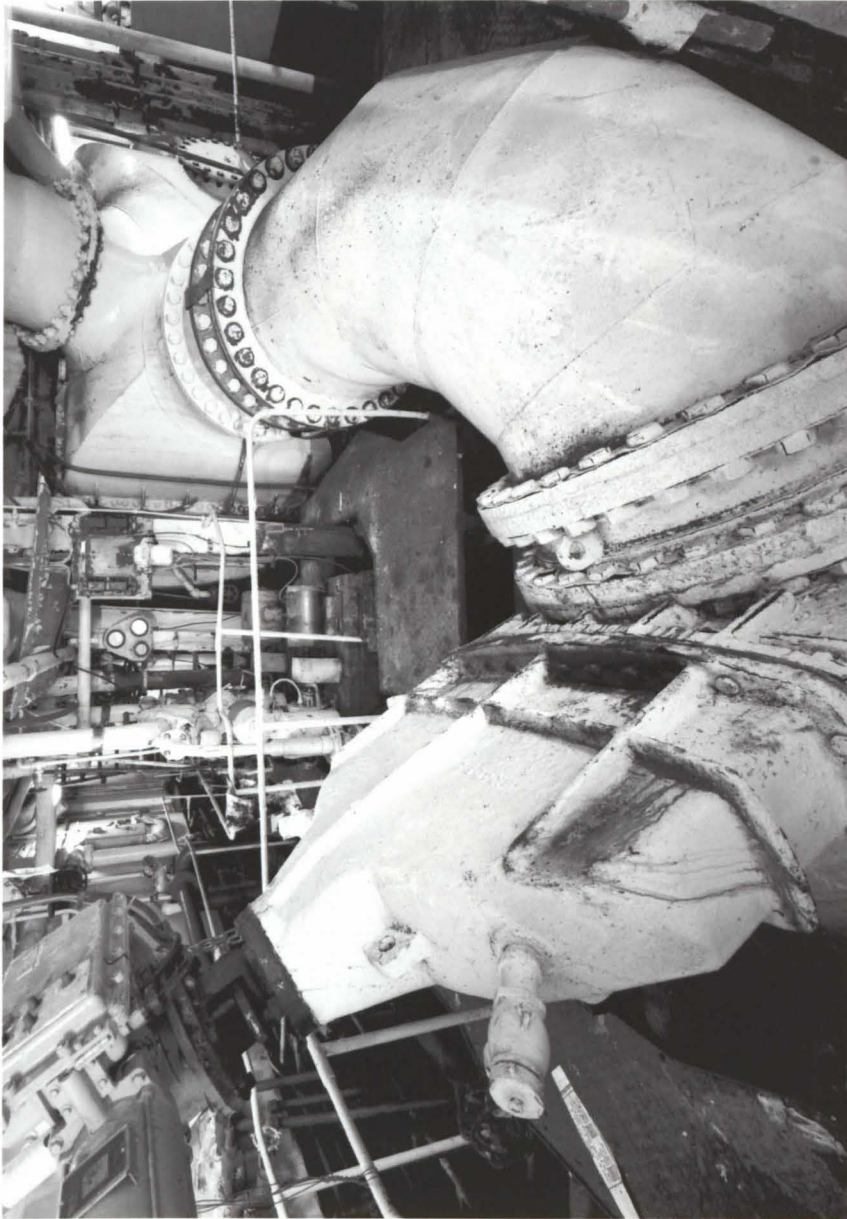

HISTORIC AMERICAN ENGINEERING RECORD
SEE INDEX TO PHOTOGRAPHS FOR CAPTION

HAER No. VA-135-044

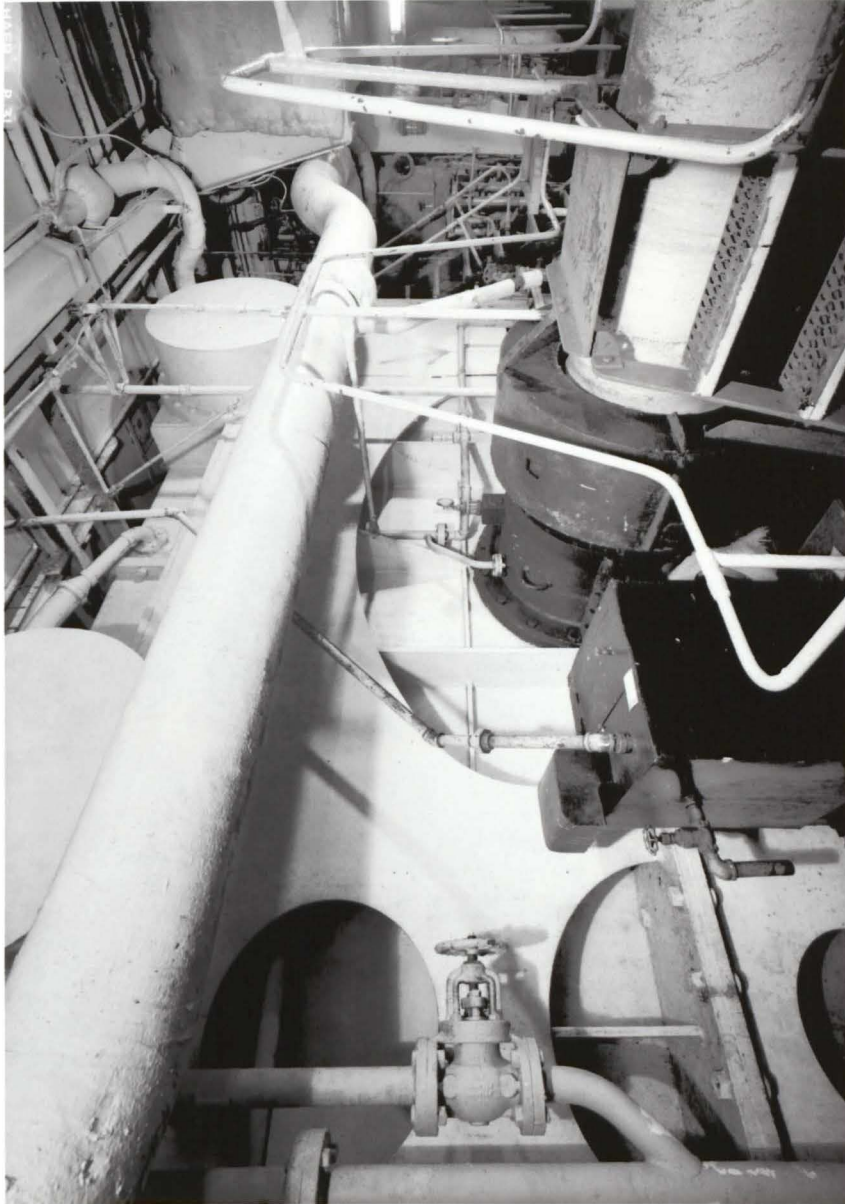

HISTORIC AMERICAN ENGINEERING RECORD
SEE INDEX TO PHOTOGRAPHS FOR CAPTION

HAER No. VA-135-045

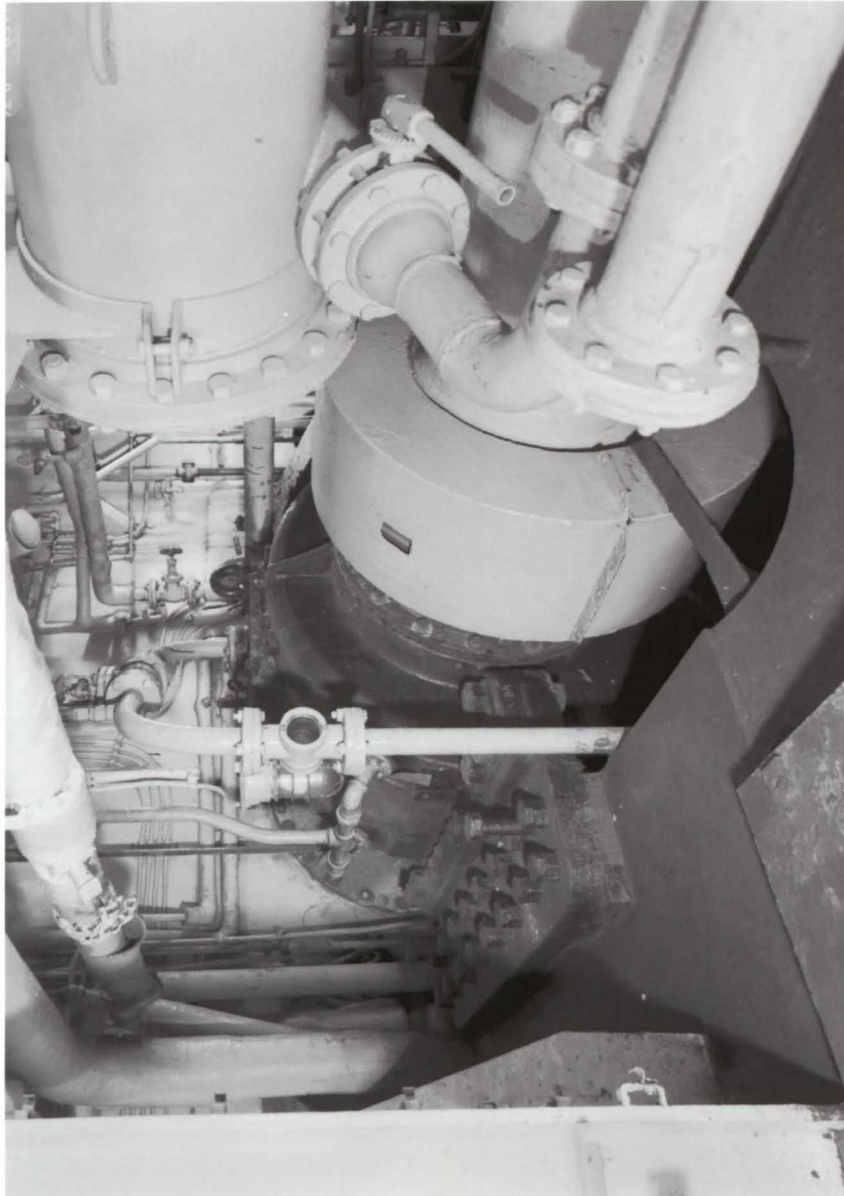

HISTORIC AMERICAN ENGINEERING RECORD
SEE INDEX TO PHOTOGRAPHS FOR CAPTION

HAER No. VA-135-046



HISTORIC AMERICAN ENGINEERING RECORD
SEE INDEX TO PHOTOGRAPHS FOR CAPTION

HAER No. VA-135-047



HISTORIC AMERICAN ENGINEERING RECORD
SEE INDEX TO PHOTOGRAPHS FOR CAPTION

HAER No. VA-135-048



HISTORIC AMERICAN ENGINEERING RECORD
SEE INDEX TO PHOTOGRAPHS FOR CAPTION

HAER No. VA-135-049



HISTORIC AMERICAN ENGINEERING RECORD
SEE INDEX TO PHOTOGRAPHS FOR CAPTION

HAER No. VA-135-050



HISTORIC AMERICAN ENGINEERING RECORD
SEE INDEX TO PHOTOGRAPHS FOR CAPTION

HAER No. VA-135-051

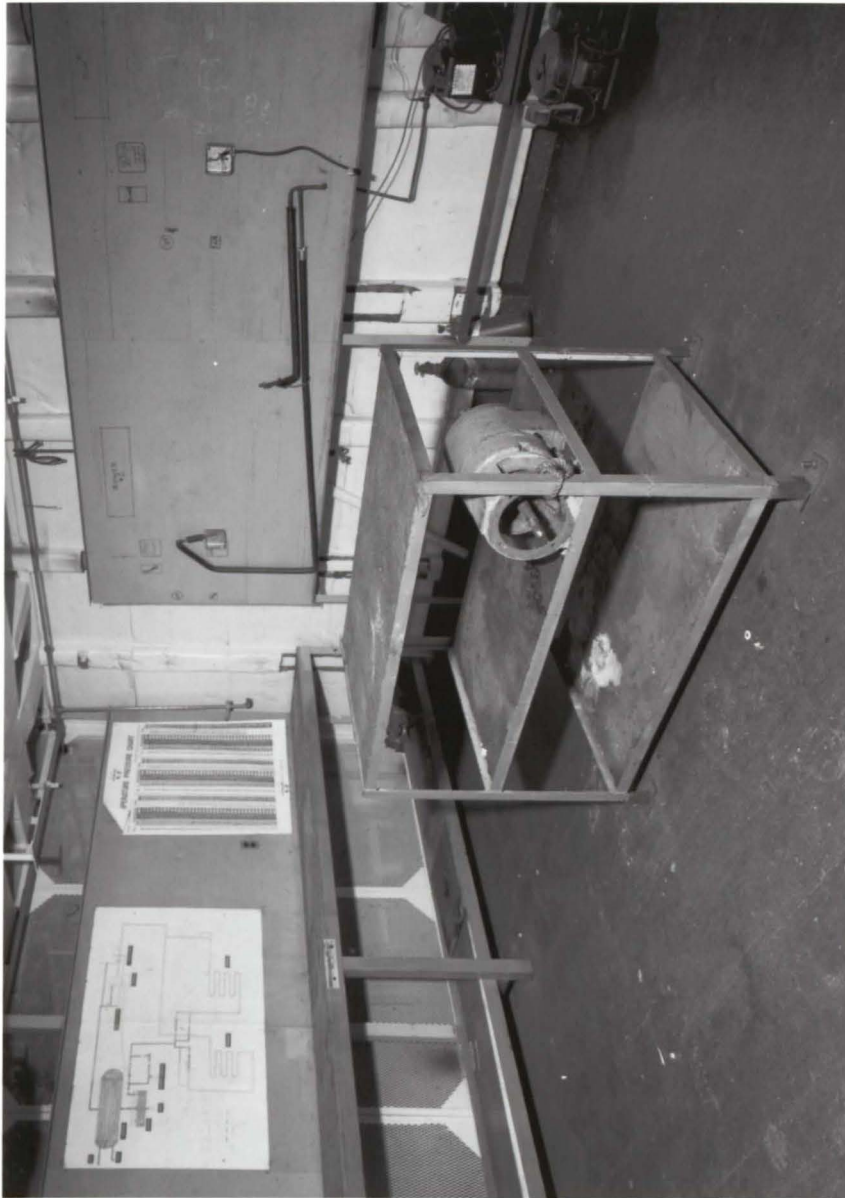

HISTORIC AMERICAN ENGINEERING RECORD
SEE INDEX TO PHOTOGRAPHS FOR CAPTION

HAER No. VA-135-052



HISTORIC AMERICAN ENGINEERING RECORD
SEE INDEX TO PHOTOGRAPHS FOR CAPTION

HAER No. VA-135-053



HISTORIC AMERICAN ENGINEERING RECORD
SEE INDEX TO PHOTOGRAPHS FOR CAPTION

HAER No. VA-135-054

